

CYCLO[®] DRIVE **6000 Series**

The Available Solution

SHI
Sumitomo Heavy Industries

Maintenance Manual

Frame Size	
Single Reduction	Double Reduction
6060	6060DA
┆	┆
6275	6275DA



<< Notes >>

- Cyclo gearmotors and reducers should be handled, installed, and maintained by trained technicians. Carefully read this maintenance manual before use.
- A copy of this maintenance manual should be sent to the actual user.
- This maintenance manual should be retained by the user for future reference.

POWER TRANSMISSION & CONTROLS GROUP
 **Sumitomo Heavy Industries, Ltd.**

SI unit

No.

CM2001E-1

Safety and Other Precautions

- Carefully read this maintenance manual and all accompanying documents before use (installation, operation, maintenance, inspection, etc.). Thoroughly understand the machine, information about safety, and all precautions for correct operation. Retain this manual for future reference.
- Pay close attention to the "DANGER" and "CAUTION" warnings regarding safety and proper use.



: Improper handling may result in physical damage, serious personal injury and/or death.



: Improper handling may result in physical damage and/or personal injury.

Matters described in  CAUTION may lead to serious danger depending on the situation. Be sure to observe important matters described herein.



DANGER

- Transport, installation, plumbing, wiring, operation, maintenance, and inspections should be performed by trained technicians; otherwise, electric shock, injury, fire, or damage to the equipment may result.
- When using the equipment in conjunction with **an explosion proof motor**, a technician with electrical expertise should supervise the transport, installation, plumbing, wiring, operation, maintenance and inspection of the equipment so as to avoid a potentially hazardous, situation that may result in electrical shock, fire, explosion, personal injury and/or damage to the equipment.
- When the unit is to be used in a system for human transport, a secondary safety device should be installed to minimize chances of accidents resulting in personal injury, death, or damage to the equipment.
- When the unit is to be used for an elevator, install a safety device on the elevator side to prevent it from falling; otherwise, personal injury, death, or damage to the equipment may result.

How to Refer to the Maintenance Manual

•This maintenance manual is common for both Cyclo gearmotor and reducer. The symbols shown below appear in the upper right corner of each page to indicate the classification. Read the applicable pages. On **COMMON** pages, these symbols identify distinctions between gearmotors and reducers.

•Refer to the brake maintenance manual (Cat. No.MM0202E) for the handling of **gearmotors with a brake**.

Specifications	Common specifications	Gearmotor	Reducer
Symbol	COMMON		

CONTENTS

1. Inspection Upon Delivery.....	3
2. Storage	7
3. Transport	7
4. Installation	8
5. Coupling with Other Machines	9
6. Wiring 	11
7. Operation	15
8. Daily Inspection and Maintenance	16
9. Disassembly and Assembly	25
10. Troubleshooting	28
11. Construction Drawing	30
12. List of Bearings and Oil Seals	32
13. Warranty	36

1. Inspection Upon Delivery

⚠ CAUTION

- Unpack the unit after verifying that it is positioned right side up; otherwise, injury may result.
- Verify that the unit received is in fact the one you ordered. Installing the wrong unit may result in personal injury or equipment damage.
- Do not remove the rating plate.

Verify the items listed below upon receiving the Cyclo gearmotor or reducer. If a nonconformity or problem is found, contact our nearest agent, distributor, or sales office.

- (1) Does the information on the rating plate conform to what you ordered?
- (2) Was there any part broken during transport?
- (3) Are all bolts and nuts tightened firmly?

1-1) How to Refer to the Rating Plate

There are two types of rating plates, Type I and Type II. Some typical plates are shown below; refer to the proper one.

- When making an inquiry, advise us of 1 the type of gearmotor or reducer, 2 reduction ratio, and 3 serial No.

Gearmotor 

(1) Rating Plate Type I : Gearmotor

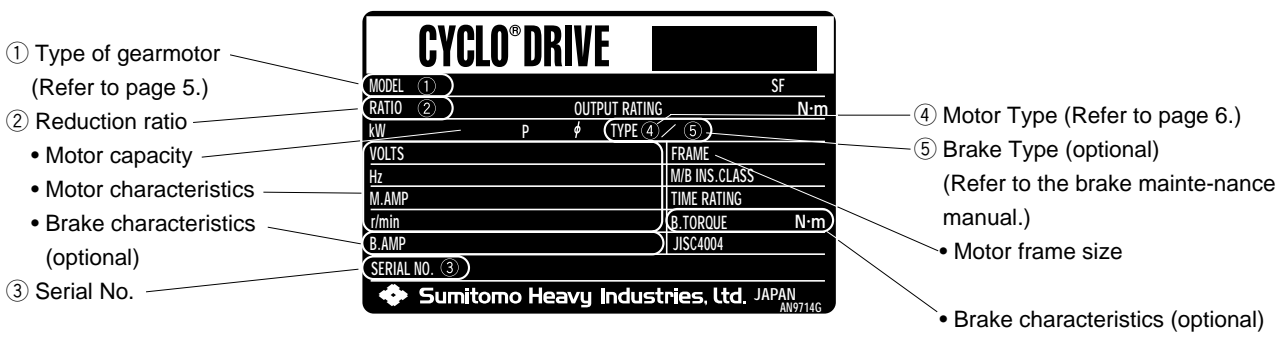

Fig.1 Gearmotor Rating Plate (Type I)

(2) Rating Plate Type II : Reducer with Motor

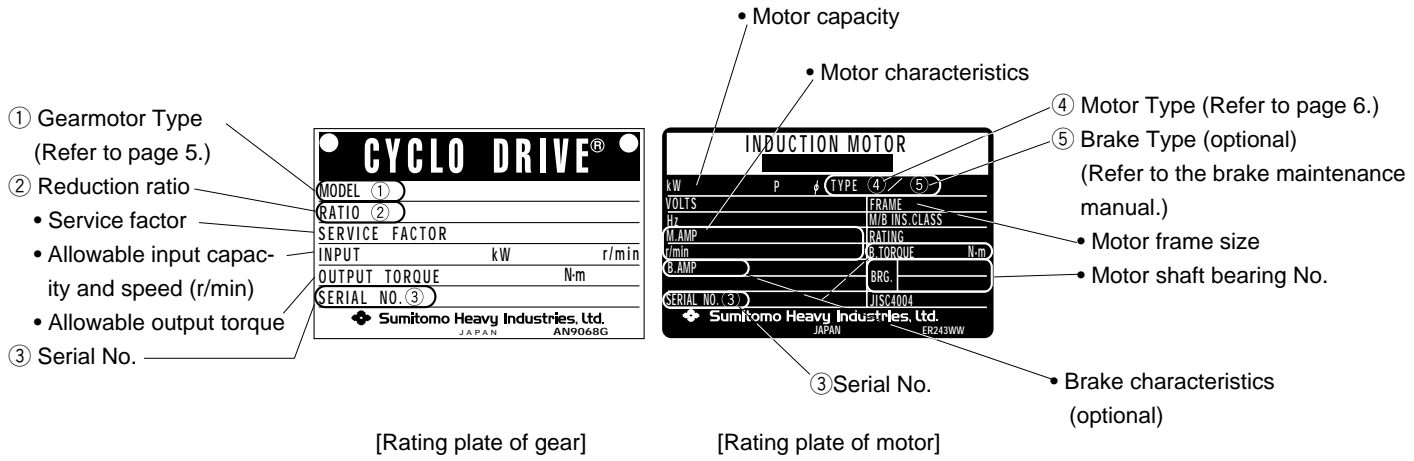

Fig.2 Rating Plates of Reducer with Motor (Type II)

Reducer



(1) Rating Plate Type I

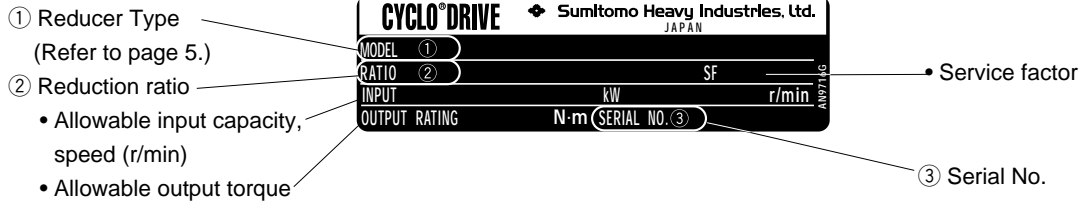

Fig.3 Rating Plate of Reducer (Type I)

(2) Rating Plate Type II

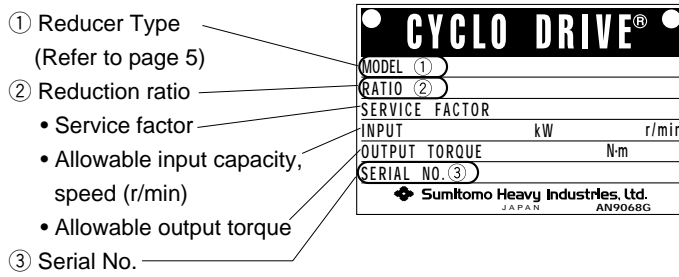

Fig.4 Rating Plate of Reducer (Type II)

1-2) Lubrication Method COMMON

Refer to "8-2. Confirmation of Lubrication Method" on page 17 to confirm the lubrication method.

• **Oil-lubricated** models are shipped without oil. Units must be filled with the proper amount of recommended oil prior to start-up.

1-3) Nomenclature of Gearmotor or Reducer

Respective codes and cyclo nomenclature are shown below. Please verify that the type of gearmotor or reducer you received conforms to what you ordered.

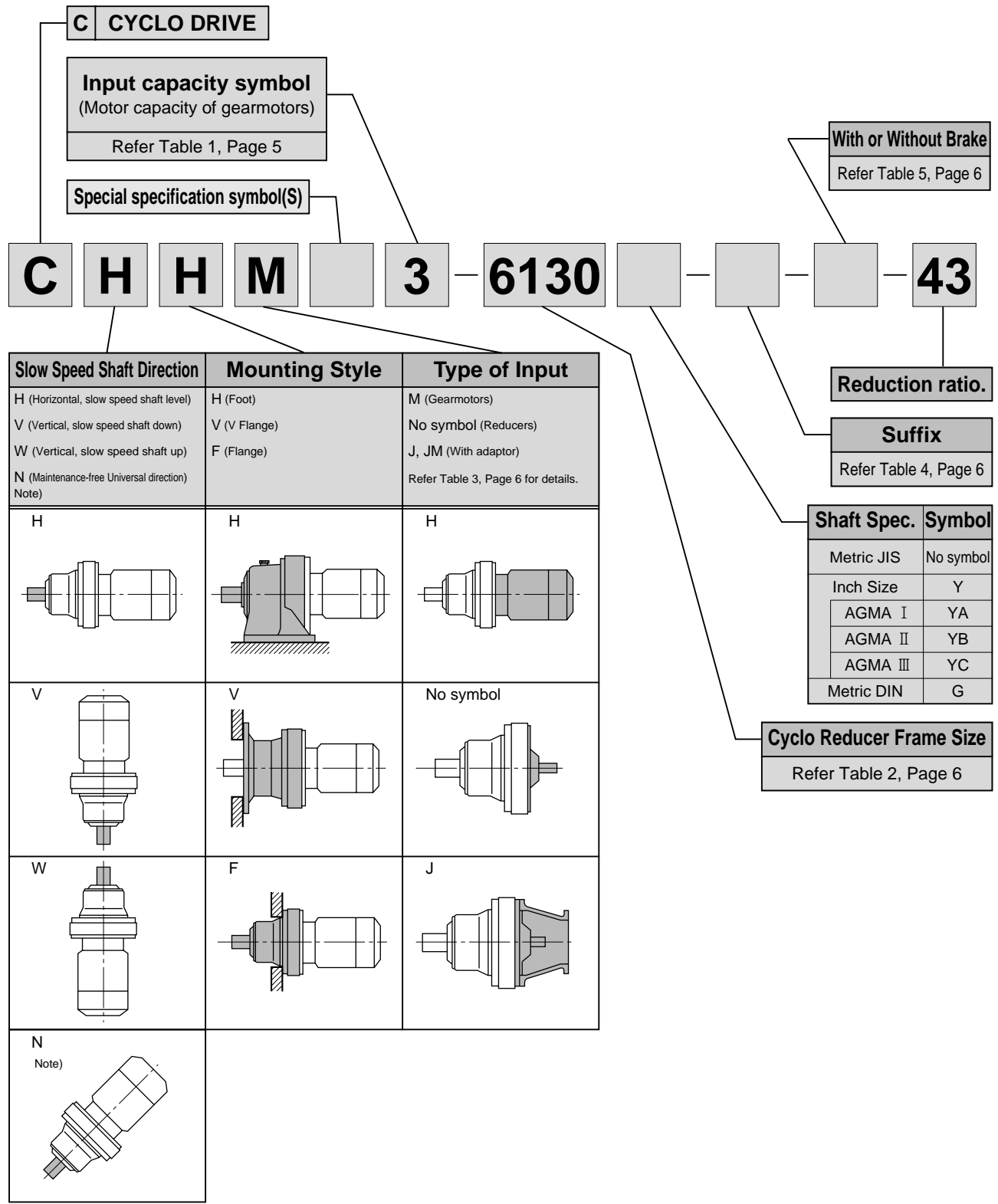

Note: N-Universal Mounting Maintenance-free is for Frame Size up to 6125 (Single stage), 6125DB (Double stage).

Table1 Input Capacity Symbol (Motor capacity in case of gearmotors).

4P	Capacity sympol	01	02	03	05	08	1	1H	2	3	4	5
	kW (HP)	0.1(1/8)	0.2(1/4)	0.25(1/3)	0.4(1/2)	0.55(3/4)	0.75(1)	1.1(1.5)	1.5(2)	2.2(3)	3.0(4)	3.7(5)
	Capacity sympol	8	10	15	20	25	30	40	50	60	75	100
	kW (HP)	5.5(7.5)	7.5(10)	11(15)	15(20)	18.5(25)	22(30)	30(40)	37(50)	45(60)	55(75)	75(100)
6P	Capacity sympol	206	256	306	406	506	606	756	1006	1256	1506	1756
	kW (HP)	15(20)	18.5(25)	22(30)	30(40)	37(50)	45(60)	55(75)	75(100)	90(125)	110(150)	132(175)

Table 2 Cyclo Reducer Frame Size.

Single Reduction	Single Reduction	Double Reduction	(Output side+ Input side)	Double Reduction	(Output side+ Input side)	Double Reduction	(Output side+ Input side)
6060	614H	6060DA	6060+6060	6140DC	6140+6105	6190DA	6190+6125
6065	6160	6065DA	6065+6065	6145DA	6145+6075	6190DB	6190+6135
6070	6165	6070DA	6070+6065	6145DB	6145+6095	6195DA	6195+6125
6075	616H	6075DA	6075+6065	6145DC	6145+6105	6195DB	6195+6135
6080	6170	6090DA	6090+6075	6160DA	6160+6095	6205DA	6205+6125
6085	6175	6095DA	6095+6075	6160DB	6160+6105	6205DB	6205+6135
6090	6180	6100DA	6100+6075	6160DC	6160+6125	6215DA	6215+6135
6095	6185	6105DA	6105+6075	6165DA	6165+6095	6215DB	6215+6165
6100	6190	6120DA	6120+6075	6165DB	6165+6105	6225DA	6225+6135
6105	6195	6120DB	6120+6095	6165DC	6165+6125	6225DB	6225+6175
610H	6205	6125DA	6125+6075	6170DA	6170+6095	6235DA	6235+6165
6110	6215	6125DB	6125+6095	6170DB	6170+6105	6235DB	6235+6185
6115	6225	6130DA	6130+6075	6170DC	6170+6125	6245DA	6245+6165
6120	6235	6130DB	6130+6095	6175DA	6175+6095	6245DB	6245+6185
6125	6245	6130DC	6130+6105	6175DB	6175+6105	6255DA	6255+6175
612H	6255	6135DA	6135+6075	6175DC	6175+6125	6255DB	6255+6195
6130	6265	6135DB	6135+6095	6180DA	6180+6105	6265DA	6265+6195
6135	6275	6135DC	6135+6105	6180DB	6180+6135	6275DA	6275+6195
6140		6140DA	6140+6075	6185DA	6185+6105		
6145	H type is option.	6140DB	6140+6095	6185DB	6185+6135		

Table3 Type of Motor Connection

Type of Motor Connection	Without Motor	With Motor
Integral Motor		M
Free Shaft	-	
W/C-Face Adaptor	J	JM
W/Quill I/P Adaptor	X	XM
Beier	B	BM
With Clutch Brake		CM
With Fluid Coupling		RM

Table 4 Suffix Designation

Reducer Specification	Symbol	Motor Specification	Symbol
Torque Limiter	TL	AF Motor	AV
High Cap Brg.	R1	Servo Motor	SV
High Cap. Brg. Ductile Casing	R2	DC Motor	DV
Baseplate	BP	3-phase Motor	Blank
HH Type Ceiling	H1	Single-phase Motor	SG
Modification Left Wall	H2		
Modification Right Wall	H3		

Table5 Brake (Integral Only)

Brake	Symbol
NO	
YES	B

1-4) Type of Motor

Respective codes and motor nomenclature are shown below. Please verify that the type of gearmotor you received conforms to what you ordered.

• For Cyclo **with a servo motor**, **DC motor** or **Vector motor**, refer to the respective motor maintenance manual.

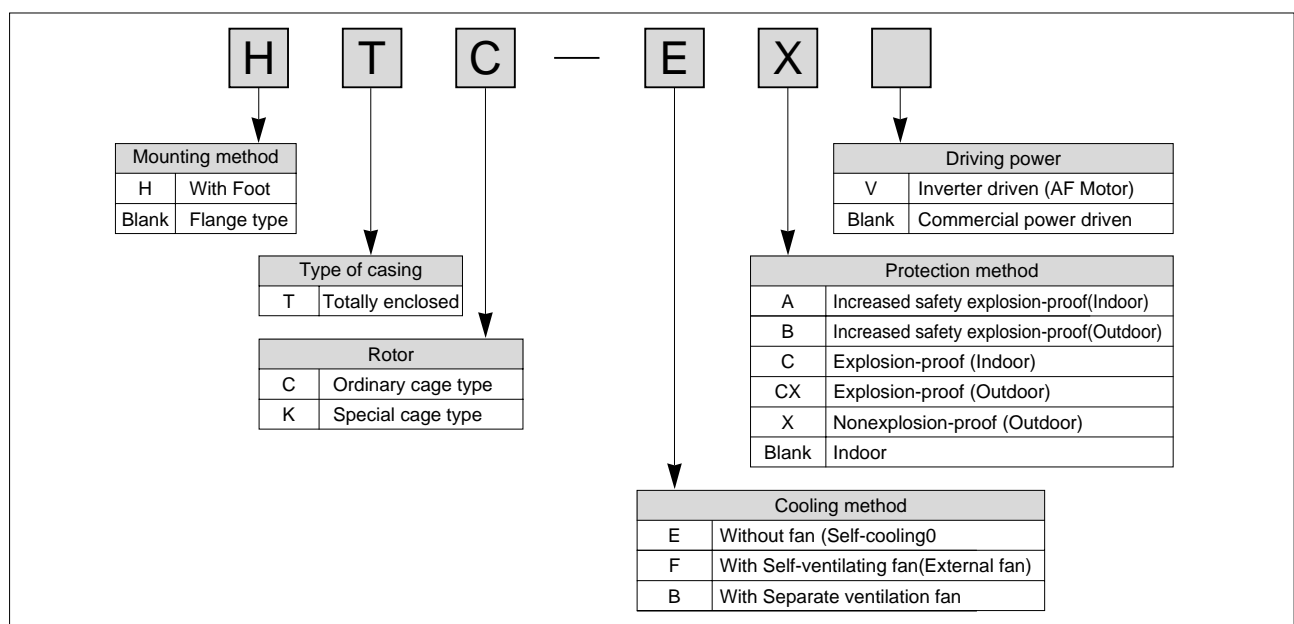

2. Storage

When storing Cyclo gearmotors or reducers for any extended period of time, consider the following important points:

2-1) Storage Location

Store the unit in a clean, dry place indoors.

- Avoid storage outdoors or in places with humidity, dust, sudden temperature changes or corrosive gas.

2-2) Storage Period

- (1) Storage period should be less than the "Rust-Proofing period" listed below.
- (2) When the storage period exceeds the standard "rust-proofing period", special rust-proofing is necessary. Contact the factory for details.
- (3) Export models need export rust prevention. Contact the factory for details.
- (4) Standard rust-proofing specification:
 - ① Outside rust-proofing
Before shipment, rust-proofing treatment is administered. Check the effect of rust-proofing, whenever necessary it should be administered.
 - ② Fig Inside rust-proofing

Lubrication	Grease lubricated models	Oil lubricated models
Rust-proofing period	1 Year	6 Months (Note ; 1)
Storage condition	Generally to be stored inside the shop or warehouse, relatively free of humidity, dust, extreme temperature fluctuation, corrosive gas and similar atmosphere.	

2-3) Use After Storage

- (1) Oil seals will deteriorate when exposed to high temperatures and UV rays. Inspect the oil seals before operation.
Replace the oil seals after long-term storage if there is any sign of deterioration.
- (2) After starting the Cyclo, Verify that there is no abnormal sound, vibration, or heat rise. If supplied as a brakemotor, check that the brake operates properly. If any anomaly is observed, contact our nearest agent, distributor, or sales office.

3. Transport

⚠ DANGER

- Do not stand directly under a unit suspended by a crane or other lifting mechanism; otherwise, injury or death may result.

⚠ CAUTION

- Exercise ample care so as not to drop the gearmotor or reducer. When a hanging bolt or hole is provided, be sure to use it. After mounting a Cyclo unit to the equipment, do not hoist the entire machine using the hanging bolt or hole; otherwise, personal injury or damage to the equipment and/or lifting device may result.
- Before hoisting, refer to the rating plate, crate, outline drawing, catalog, etc. for the weight of the Cyclo gearmotor or reducer. Never hoist a unit that exceeds the rating of the crane or other mechanism being used to lift it; otherwise, personal injury or damage to the equipment and/or lifting device may result.

4. Installation

⚠ DANGER

- Do not use a standard unit in an explosive atmosphere (which is likely to be filled with explosive gas or steam). Under such conditions, an explosion-proof motor should be used; otherwise, electric shock, personal injury, explosion fire, or damage to the equipment may result.
- Since the inverter itself is not explosion-proof, install an **inverter-driven, explosion-proof type motor** in a place free from explosive gas; otherwise, electric shock, personal injury, explosion fire, or damage to the equipment may result.

⚠ CAUTION

- Do not use the Cyclo gearmotor or reducer for purposes other than those shown on the rating plate or in the manufacturing specifications; otherwise, electric shock, personal injury, or damage to the equipment may result.
- Do not place flammable objects around the gearmotor; otherwise, fire may result.
- Do not place any object around the gearmotor or reducer that will hinder ventilation. Insufficient ventilation can cause excessive heat build-up that may result in burns or fire.
- Do not step on or hang from the gearmotor or reducer; otherwise injury may result.
- Do not touch the shaft end of the gearmotor or reducer, inside keyways, or the edge of the motor cooling fan with bare hands; otherwise, injury may result.
- When the unit is used in food processing applications vulnerable to oil contamination, install an oil pan or other such device to cope with oil leakage due to breakdown or failure; otherwise, oil leakage may damage products.

4-1) Installation Location

- Ambient temperature : -10°C to +40°C
- Ambient humidity : 85% max.
- Altitude : 1000m max.
- Ambient atmosphere : There should be no corrosive gas, explosive gas, or steam.

The location should be well ventilated without dust.

Installation location : Indoors, with minimum dust and no water splashing.

- Units made to special specifications are necessary for installation under conditions other than the above.
- Units made according to the outdoor, explosion-proof or other specifications can be used under the specified conditions without any problem.
- Install units where inspection, maintenance, and other such operations can be easily carried out.
- Install units on a sufficiently rigid base.

4-2) Installation Angle

Table6 Installation Angle

Grease lubricated model	Free
Oil lubricated model	Low speed shaft Horizontal or Vertical (Refer to page 5. Contact us inclined installation.)

When the unit is made according to your specification for inclined installation, do not install it at any angle other than the specified angle. (The shaft orientation of the standard **outdoor gearmotor** is horizontal. Contact us for other shaft orientations.)

- Do not remove the eyebolt on the motor. Should the eyebolt be removed, put a bolt into the threaded hole or take other water-proofing measures to prevent water from entering the motor through the threaded hole.

4-3) Severe Load Conditions

When vibration is strong and start-stop operation is frequent, it is recommended to use minimum strength class 8.8 foundation bolts as per JIS 1051.

5. Coupling with Other Machines

⚠ CAUTION

- Confirm the rotation direction before coupling the unit with the driven machine. Incorrect rotation direction may cause personal injury or damage to the equipment.
- When operating the gearmotor or reducer alone (uncoupled), remove the key that is temporarily attached to the output shaft; otherwise, injury may result.
- Cover the rotating parts; otherwise, injury may result.
- When coupling the gearmotor or reducer with a load, check that the centering, the belt tension and parallelism of the pulleys are within the specified limits. When the unit is directly coupled with another machine, check that the direct coupling accuracy is within the specified limits. When a belt is used for coupling the unit with another machine, check the belt tension. Correctly tighten bolts on the pulley and coupling before operation; otherwise, injury may result because of misalignment.

5-1) Confirming Rotation Direction

Gearmotor



Figure 5 shows the rotation direction of the output shaft when wires are connected as shown in Fig.10 on page 13.

Fig.5 Rotation Direction of Slow Speed Shaft (Gearmotor)

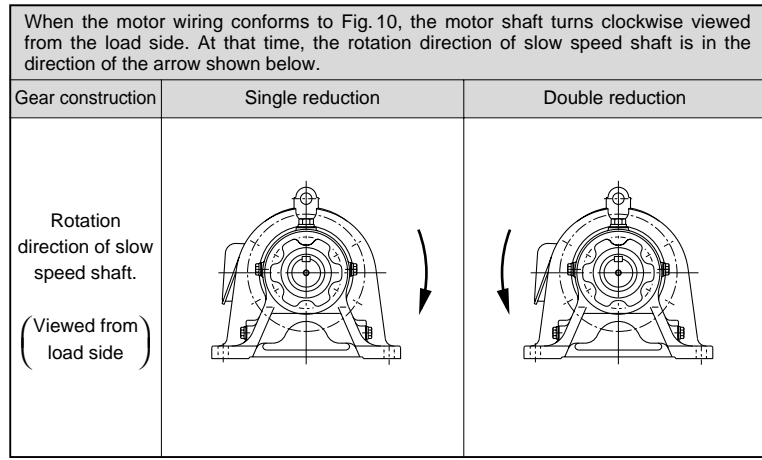

- For reverse rotation, change the positions of R and T of the motor wiring.

Reducer



Table 8 Rotation Direction of Slow Speed Shaft (Reducer)

Gear construction	Single reduction	Double reduction
Rotation direction of slow speed shaft	As compared with high speed shaft, opposite direction.	As compared with high speed shaft, same direction.

Table 7 Frame Sizes

Frame size	
Single reduction	Double reduction
606□	606□DA
607□	607□DA
608□	—
609□	609□DA
610□	610□DA
611□	—
612□	612□DA, 612□DB
613□	613□DA, 613□DB, 613□DC
614□	614□DA, 614□DB, 614□DC
616□	616□DA, 616□DB, 616□DC
617□	617□DA, 617□DB, 617□DC
618□	618□DA, 618□DB
619	619□DA, 619□DB
6205	6205DA, 6205DB
6215	6215DA, 6215DB
6225	6225DA, 6225DB
6235	6235DA, 6235DB
6245	6245DA, 6245DB
6255	6255DA, 6255DB
6265	6265DA
6275	6275DA

0, 5, or H is inserted in □.

5-2) Coupling Installation

- When installing a coupling, do not impact or apply excessive thrust load to the shaft ; otherwise, the bearing may be damaged or collar may be left.
- Thermal shrinking is the recommended installation method.

(1) When Using a Coupling

The accuracy of the dimensions (A, B, and X) shown in Fig.6 should be within the tolerance shown in Table 9.

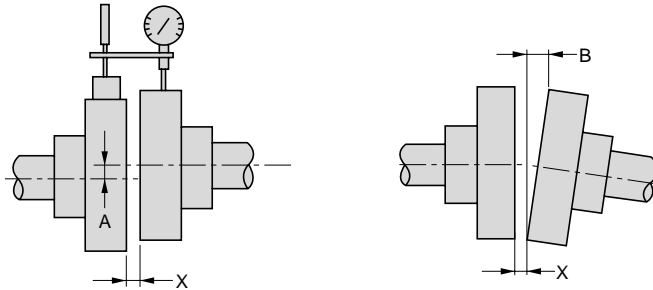

Fig. 6

Table 9 Centering Accuracy of Flexible Coupling

Dimension A Tolerance	0.1mm or manufacturer's specification
Dimension B Tolerance	0.1mm or manufacturer's specification
X dimension	Manufacturer's specification

(2) When Using a Chain Sprocket and Gear

- The chain tension angle should be perpendicular to the shaft.
- Refer to the chain catalog for the chain tension.
- Select sprockets and gears whose pitch diameter are three times the shaft diameter or greater.
- Install sprocket and gears so that their point of load application will be closer to the gearmotor or reducer side with respect to the length of the shaft. (Fig.7)

(3) When Using a V-belt

- Excessive V-belt tension will damage the shaft and bearing. Refer to the V-belt catalog for proper tension.
- The parallelism and eccentricity (β) between two pulleys should be within $20'$. (Fig.8)
- Use a matched set with the same circumferential length when more than one belt is to be installed.

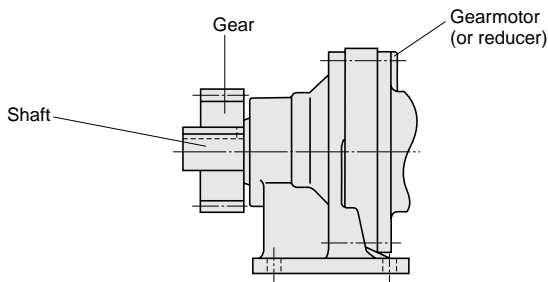

Fig. 7

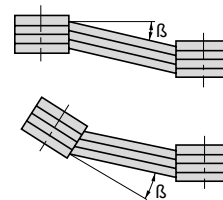

Fig. 8



6. Wiring

- Wiring for **SUMITOMO standard 3-phase motor** is shown below.
Refer to the respective instruction manual **for brakemotors** , **servomotors** , **DC motors** and **motors made by other companies** when they are used.

⚠ DANGER

- Do not handle the unit when cables are live. Be sure to turn off the power; otherwise, electric shock may result.
- Connect a power cable to the unit according to the diagram shown inside the terminal box or in the maintenance manual; otherwise, electric shock or fire may result.
- Do not forcibly curve, pull, or clamp the power cable and lead wires; otherwise, electric shock or fire may result.
- Correctly ground the grounding bolt; otherwise, electric shock may result.
- The lead-in condition of an **explosion-proof type motor** shall conform to the facility's electrical codes, extension regulations and explosion-proofing guide, as well as the maintenance manual; otherwise, electric shock, personal injury, explosion, fire or damage to the equipment may result.

⚠ CAUTION

- When wiring, follow the facility's electrical codes and extension regulations; otherwise, burning, electric shock, injury, or fire may result.
- The motor is not equipped with a protective device. However, it is compulsory to install an overload protector according to facility electrical codes. It is recommended to install other protective devices (earth leakage breaker, etc.), in addition to an overload protector, in order to prevent burning, electric shock, injury, and fire.
- Never touch the terminals when measuring insulation resistance; otherwise, electric shock may result.
- **When using a star-delta starter** , select one with an electromagnetic switch on the primary side (3-contact type); otherwise, fire may result.
- When using **400V-class inverter** to drive the motor, mount a suppresser filter or reactor on the inverter side, or provide reinforced insulation on the motor side; otherwise, dielectric breakdown may cause fire or damage to the equipment.
- **When driving an explosion-proof type motor with an inverter** , use one inverter for one motor. Use the approved inverter for the motor.
- When measuring the insulation resistance of an **explosion-proof type motor** , confirm that there is no gas, steam, or other explosive substance in the vicinity, in order to prevent possible explosion or ignition.

- Long cables cause voltage to drop. Select cables with appropriate diameter so that the voltage drop will be less than 2%.
- After wiring **outdoor and explosion-proof type motors** , check that terminal box mounting bolts are not loose, and correctly attach the terminal box cover.

6-1) Attaching and Detaching the Terminal Cover (**0.1~04kW 3-phase motor**)

(1) Detaching

As shown in Fig.9, hold both sides of the terminal box and pull it towards you. The cover will detach.

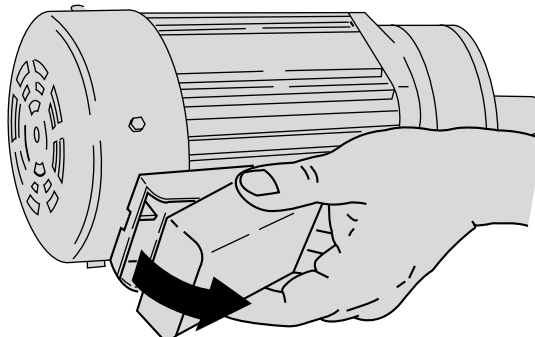

Fig. 9

(2) Attaching

Press the terminal box cover onto the terminal box case until it snaps into place.



6-2) Measuring Insulation Resistance

- When measuring the insulation resistance, disconnect the motor from the control panel. Check the motor separately.

Measure the insulation resistance before wiring. The insulation resistance (R) varies according to the motor output, voltage, type of insulation, coil temperature, humidity, dirt, period of operation, test electrification time, etc. Usually, the insulation resistance exceeds the values shown in Table 10.

Table 10 Insulation Resistance

Motor voltage	Megohmmeter voltage	Insulation resistance (R)
Low-voltage motor of 600V or less	500V	1M (Ω) or more
High-voltage motor of 3000V or more	1000V	5M (Ω) or more

Reference : The following equations are shown in JEC-2100.

$$R \geq \frac{\text{Rated Voltage (V)}}{\text{Rated Output (kW)+1000}} \quad (\text{M}\Omega)$$

$$R \geq \frac{\text{Rated Voltage(V)+Speed(rpm)/3}}{\text{Rated Output(kW)+2000}} \quad +0.5(\text{M}\Omega)$$

A drop in insulation resistance may be attributed to poor insulation. In that case, do not turn on the power. Contact our nearest agent, distributor, or sales office.

6-3) Protection Coordination

- (1) Use a molded case circuit breaker for protection against short circuit.
- (2) Use an overload protection device that protects the unit against a surge of electric current exceeding that shown on the rating plate.
- (3) For an **explosion-proof type motor**, use an overload protector that can protect the unit within the allowable binding hour by means of the locked rotor current shown on the rating plate.



6-4) Motor Connection

Fig.10 shows the motor connection and the standard specifications for terminal codes.

Fig. 10 Motor Connection and Terminal Code (200/400V 50/60Hz, 220/440V 60Hz)

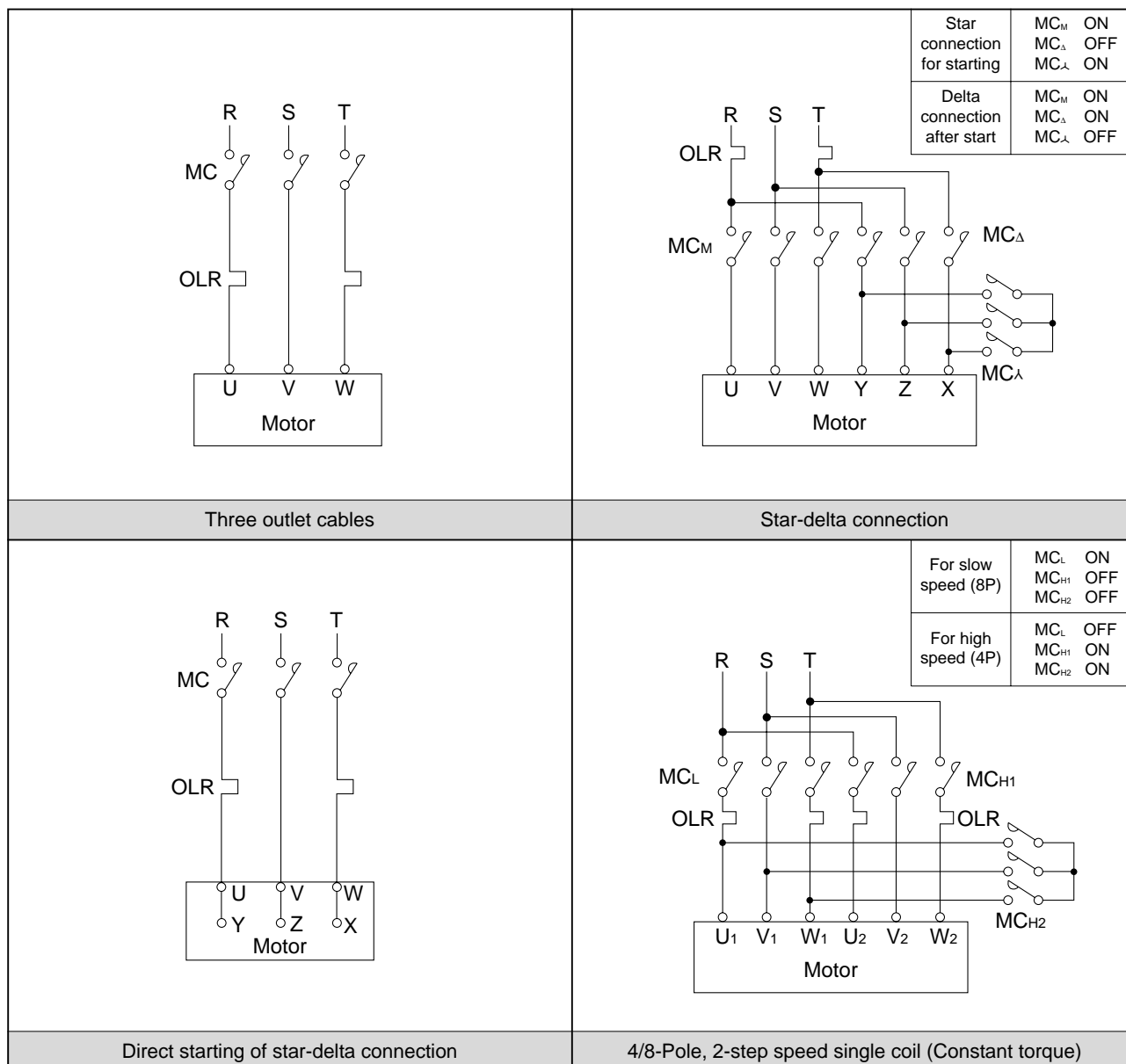

MC : Electromagnetic contactor
 OLR : Overload protection device

} — These should be furnished by the customer.

• **Observe the following for a forced ventilation type :**

- Connect the forced ventilation fan motor with the power source.
- If the fan motor is a single phase motor, the motor rotates in only one direction.
- If the fan motor is a three phase motor, it must be connected to the power source in such a way that the fan turns in the same direction as the arrow shown on the direction indicator plate.
 If rotary direction of the fan is opposite, change two of the three wires (U, V, W) with each other. (The direction of ventilation should be from opposite load side to load side.)
- For a forced ventilation type with a thermostat (Terminal code T₁, T₂), connect the thermostat with the power source. (The thermostat is a normal closed type)
- Turn-off the forced ventilation motor if the main motor will not be operating for an extended period.

6-5) Trochoid Pump Connection

⚠ CAUTION

- Conduct priming shown in the maintenance manual, before the start up of the main motor, in case of forced oil lubrication by the trochoid pump; otherwise damage to the equipment may result.
For forced oil lubrication by trochoid pump, prime the pump, as shown in the maintenance manual, before starting the main motor; otherwise, the equipment may be damaged.

- (1) Because forced lubrication by the trochoid pump is necessary for vertical type 6275, 6275DA, a separate power source should be prepared for the pump. (Refer to Table 11 and Fig.11)
- (2) Refer to Fig.12 for the trochoid pump wiring.
- (3) Establish an electrical interlocking device between the trochoid pump motor and main motor that satisfies the following two functions; (Refer to Fig.12)
 - ① Start-up time-The main motor stops when the trochoid pump stops.
 - ② During operation-The main motor stops when the trochoid pump stops for some unknown reason.
- (4) To assure optimal lubrication conditions, the trochoid pump should be started-up at least 30 seconds before the start-up of the main motor. (priming)

Table011 Trochoid Pump Specification

Cyclo drive			Trochoid pump						Note
Type	Frame size	Reduction ratio	Pump type	Pump motor	50Hz Zone		60Hz Zone		
					Discharge (ℓ /min)	Max. pressure (MPa)	Discharge (ℓ /min)	Max. pressure (MPa)	
Vertical	6275	All reduction ratio	TOP-216HBVB	0.75kW 4P	24.0	0.78	28.8	0.49	(1) Trochoid pump manufactured by Nippon Oil Pump Mfg. Ltd. is to be used as the standard pump. (2) A relief valve (Pressure set at 0.29MPa) is a standard attachment on the trochoid pump.
	6275DA	All reduction ratio	TOP-204HBVB	0.4kW 4P	6.0	1.57	7.2	1.13	

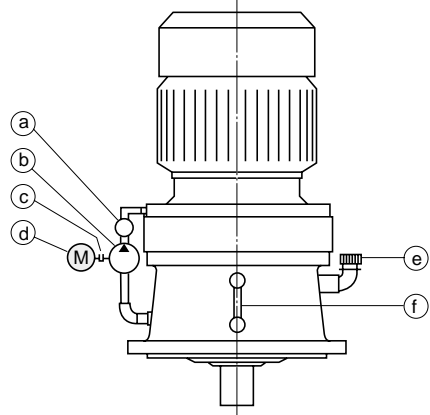

a	Pressure gauge
b	Trochoid pump
c	Coupling
d	Motor (For Trochoid pump)
e	Oil filler plug
f	Oil level gauge

Fig. 11 Trochoid Pump Construction

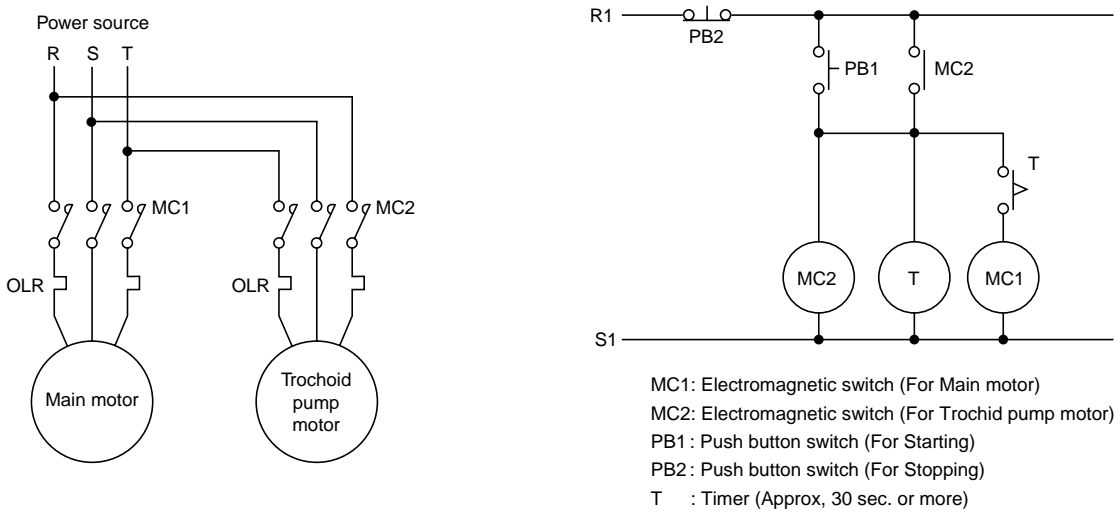

- MC1: Electromagnetic switch (For Main motor)
- MC2: Electromagnetic switch (For Trochoid pump motor)
- PB1: Push button switch (For Starting)
- PB2: Push button switch (For Stopping)
- T : Timer (Approx, 30 sec. or more)

Fig. 12 Trochoid Pump Wiring Diagram

7. Operation

⚠ DANGER

- Do not approach or touch rotating parts (output shaft, etc.) during operation; loose clothing may become caught in these rotating parts and cause serious injury or death.
- When the power supply is interrupted, be sure to turn off the power switch. Unexpected resumption of power may cause electric shock, personal injury, or damage to the equipment.
- Do not operate the unit with the terminal box cover removed. Return the terminal box cover to the original position after maintenance, in order to prevent electric shock.
- Do not open the terminal box cover when power is supplied to an **explosion-proof type motor** ; otherwise, explosion, ignition, electric shock, personal injury, fire, or damage to the equipment may result.

⚠ CAUTION

- Do not put fingers or foreign objects into the opening of the gearmotor or reducer; otherwise electric shock, personal injury, fire, or damage to the equipment may result.
- The gearmotor or reducer becomes very hot during operation. Touching the unit may result in burns.
- Do not loosen the oil filler plug during operation; otherwise, hot, splashing lubricant may cause burns.
- If any abnormality occurs during operation, stop operation immediately; otherwise, electric shock, personal injury, or fire may result.
- Do not operate the unit in excess of the rating; otherwise, personal injury or damage to the equipment may result.

• **Oil-lubricated models** are shipped without oil. Units must be filled with the proper amount of recommended oil prior to start-up.

After the unit is installed, filled with oil and properly wired, check the following before operating:

- (1) Is the wiring correct ?
- (2) Is the unit properly coupled with the driven machine ?
- (3) Are foundation bolts tightened firmly ?
- (4) Is the direction of rotation as required.
- (5) Does the oil level in **the oil-lubricated model** reach the top line of the oil gauge when the unit is at rest ?

After confirming these items without a load, gradually apply a load.

Check the items shown in Table 12.

Table 12 Items to Check During Initial Start-up and Break-in Period

Is abnormal sound or vibration generated ?	<ol style="list-style-type: none"> (1) Is the housing deformed because the installation surface is not flat ? (2) Is insufficient rigidity of the installation base generating excessive noise ? (3) Is the shaft center aligned with the driven machine ? (4) Is the vibration of the driven machine transmitted to the gearmotor or reducer ?
Is the surface temperature of the gearmotor or reducer abnormally high ?	<ol style="list-style-type: none"> (1) Is the voltage rise or drop substantial ? (2) Is the ambient temperature too high ? (3) Does the current flowing to the gearmotor exceed the rated current shown on the rating plate ?

If any abnormality is found, stop operation and contact our nearest agent, distributor, or sales office.

8. Daily Inspection and Maintenance

DANGER

- Do not handle the unit when cables are live. Be sure to turn off the power; otherwise, electric shock may result.
- Do not approach or touch any rotating parts (output shaft, etc.) during maintenance or inspection of the unit; loose clothing may become caught in these rotating parts and cause serious injury or death.
- Customers shall not disassemble or modify **explosion-proof type motors** ; otherwise, explosion, ignition, electric shock, or damage to the equipment may result.
- The lead-in condition of an **explosion-proof type motor** shall conform to the facilities electrical codes, extension regulations, and explosion-proofing guide, as well as the maintenance manual ; otherwise, explosion, ignition, electric shock, or damage to the equipment may result.

CAUTION

- Do not put fingers or foreign objects into the opening of the gearmotor or reducer; otherwise, electric shock, injury, fire, or damage to the equipment may result.
- The gearmotor or reducer becomes very hot during operation. Touching the unit with bare hands; may result in serious burns.
- Do not touch the terminal when measuring insulation resistance; otherwise, electric shock may result.
- Do not operate the unit without a safety cover in place to shield rotating parts; otherwise loose clothing may become caught in the unit and cause serious injury.
- Promptly identify and correct, according to instructions in this maintenance manual, any abnormalities observed during operation. Do not operate until abnormality is corrected.
- Change lubricant according to the maintenance manual instructions. Be sure to use factory recommended lubricant.
- Do not change lubricant during operation or immediately after stopping operation; otherwise, burns may result.
- Supply/discharge grease to/from the motor bearing according to the maintenance manual instructions. Avoid contact with rotating parts; otherwise, injury may result.
- Do not operate damaged gearmotors or reducers; otherwise, injury, fire, or damage to the equipment may result.
- We cannot assume any responsibility for damage or injury resulting from an unauthorized modification by a customer.
- Dispose of the gearmotor or reducer lubricant as general industrial waste.
- When measuring the insulation resistance of an **explosion-proof type motor** , confirm that there is no gas, steam, or other explosive substance around the unit in order to prevent explosion or ignition.

8-1) Daily Inspection

To ensure proper and continued optimum operation, use Table 13 to perform daily inspections.

Table 13 Daily Inspection

Inspection item		Details of inspection
Electric current		Is the current below the rated current shown on the rating plate ?
Noise		Is there abnormal sound ? Is there sudden change in sound ?
Vibration		Is there excessive vibration ? Does vibration change suddenly ?
Surface temperature		Is the surface temperature abnormally high ? Does the surface temperature rise suddenly ? [The temperature rise during operation differs according to the models. When the difference between the temperature of the gear surface and the ambient temperature is approx. 60°C (for size 6060-6125 it is approx. 40°C), there will be no problem if there is no fluctuation.
Oil level (Oil-lubricated model)	At rest	Does the oil level reach the top line of the oil gauge ?
	In operation	When compared to the oil level at rest, is this level different ?
	When using the trochoid pump	Is the function of oil signal or flow gauge normal ? When the function is abnormal, stop the unit and inspect it ; otherwise inadequate oil will cause poor lubrication of reduction portion, broken pump and fill-up the oil pipe.
Oil or grease leakage		Does oil or grease leak from the gear section ?
Foundation bolt		Are foundation bolts loose ?
Chain and V-belt		Are chain and V-belt loose ?

When any abnormality is found during the daily inspection, take corrective measures listed in section 10, Troubleshooting (pages 28 and 29.) If the abnormality cannot be corrected, contact our nearest agent, distributor or sales office.

8-2) Confirmation of Lubrication Method

• Refer to the applicable items regarding maintenance. Improper maintenance may decrease unit life.

- (1) Refer to Table 14 to confirm the gear lubrication method for your unit.
- (2) Table 15 lists pages that can be referenced regarding lubrication maintenance.

Table 14 Lubrication Method for Respective Gear Types (For driving at standard input speed)

Contact us when the input speed is not standard.

Single reduction	Frame size	606□	607□	608□	609□	610□	611□	612□	613□	614□	616□	617□	618□	619□	6205	6215	6225	6235	6245	6255	6265	6275	
	Horizontal	Grease									Oil bath												
	Vertical	Grease									Oil bath			Plunger pump (Self-lubrication)									
Double reduction	Frame size	606□DA	607□DA	609□DA	610□DA	612□DA	612□DB	613□DA	613□DB	613□DC	614□DA	614□DB	614□DC	616□DA	616□DB	617□DA	617□DB	618□DA					
	Horizontal	Grease									Grease												
	Vertical	Grease									Grease												
	Frame size	616□DC	617□DC	618□DB	619□DA	619□DB	6205DA	6205DB	6215DA	6215DB	6225DA	6225DB	6235DA	6235DB	6245DA	6245DB	6255DA	6255DB	6265DA	4275DA			
	Horizontal	Oil bath																					
Vertical	Reduction ratio	~473	~481	~1015	~2065			~1849			~2537												
		Plunger pump (Self-lubrication)																					
	Reduction ratio	559~	1003~	1247~	2537~			2065~			3045~												
	Grease																						

Maintenance-free type
 Forced lubrication by trochoid pump. Refer to "6-5 Trochoid Pump Connection" on page 14.
 0, 5, or H is inserted in □.

Table 15 Maintenance Manual Pages that can be Referenced Regarding Lubrication Maintenance

	Lubrication method	Supply of oil/grease before initial operation after purchase	Pages where maintenance method is shown						
			Oil/grease change period	Recommended oil/grease	Qty of oil/grease	Disposal of oil/grease	Parts		
Gear	Oil	Oil bath	Necessary	8-3) (1) P18	8-3) (2) P18	8-3) (3) P18	8-3) (4), (5) P19, 20	8-6) P24	
		Plunger pump lubrication							Self-lubrication
		Trochoid pump lubrication							Forced lubrication
Grease	Maintenance-free	Unnecessary	8-4) (1) P20	8-4) (2) P20	8-4) (3) P21	8-4) (4) P21			
	Except for maintenance-free						Self-lubrication		
Motor shaft bearing	Grease	—	Unnecessary	8-5) (1) P22	8-5) (2) P23	8-5) (1) P22	8-5) (3) P23		

8-3) Oil Supply and Change for **Oil-lubricated Gear**

(1) Oil Change Interval

Table 16 Oil Change Interval

Change interval	Operation
3000hrs operation or 6 months, whichever comes.	Checking lubrication oil
10000hrs operation or 3 Years, first.	Changing lubrication oil

Consult us when there are special ambient conditions, like Low or High temperature, and special specifications are required.

(2) Recommended Lubricants

Be sure to use a lubricant recommended by our company.

Table 17 Recommended Lubricants (Equivalent to SP type industrial high-Pressure gear oil or JIS K2219)

Ambient temperature (°C)	Cosmo Oil	Nippon Oil Mitsubishi	Idemitsu Kosan	Japan Energy	Gulf Oil	Esso General	Mobil Oil	Shell Oil	Caltex Oil	BP Oil
-10 ~ 5	Cosmo Gear SE 68	Bonnock M 68	Daphe Super Gear Oil 68	JOMO Reductase 68	EP Lubricant HD 68	Spartan EP 68	Mobil gear 626 (ISO VG 68)	Omala Oil 68		Energol GR-XP 68
0 ~ 35	Cosmo Gear SE 100, 150	Bonnock M 100, 150	Daphe Super Gear Oil 100, 150	JOMO Reductase 100, 150	EP Lubricant HD 100 HD 150	Spartan EP 100 EP 150	Mobil gear 627, 629 (ISO VG 100, 150)	Omala Oil 100, 150	Meropa 100, 150	Energol GR-XP 100 GR-XP 150
30 ~ 50	Cosmo Gear SE 220, 320, 460	Bonnock M 220~460		JOMO Reductase 220~460	EP Lubricant HD 220 HD 320 HD 460	Spartan EP220~460	Mobil gear 630, 634 (ISO VG 220~460)	Omala Oil 220~460	Meropa 220, 320, 460	Energol GR-XP 220 GR-XP 320 GR-XP 460

- ① During winter or at comparatively low temperatures, use a lubricant with low viscosity.
- ② Table 18 shows allowable viscosities. The viscosity you use should not exceed the standard range shown.

Table 18 Allowable Viscosities

Min. Allowable Viscosity	15mm ² /S or more at operating oil temperature		Viscosity that ensures oil film strength adequate for load transmission
Max. Allowable Viscosity	Oil-bath lubrication	4300mm ² /S max.	Viscosity necessary for start-up of the Cyclo
	Oil-bath lubrication	2200mm ² /S max.	Viscosity necessary for start-up of plunger pump and trochoid pump

- ③ For smooth start-up, use oil with a pour point 5°C lower than the ambient temperature.
- ④ When operating conditions vary greatly, use oil with a high viscosity index that meets the requirements of ② and ③.
- ⑤ When the unit is operated in ambient temperatures either below or above the 0~40°C range, it may be necessary to either preheat or cool the lubricant and/or use special parts. Contact us for details.

(3) Oil Quantity

Table 19 shows approx. quantity of oil. Be sure to check the oil level through the oil gauge.

Table 19 Approx. Qty of Oil (ℓ)

Single reduction	Frame size	613□	614□	616□	617□	618□	619□	6205	6215	6225	6235	6245	6255	6265	6275						
	Horizontal shaft		0.7	0.7	1.4	1.9	2.5	4.0	5.5	8.5	10	15	16	21	29	56					
Vertical shaft		1.1	1.1	1.0	1.9	2.0	2.7	5.7	7.5	10	12	15	42	51	(60)						
Double reduction	Frame size	616□DC	617□DC	618□DB	619□DA	619□DB	6205DA	6205DB	6215DA	6215DB	6225DA	6225DB	6235DA	6235DB	6245DA	6245DB	6255DA	6255DB	6265DA	6275DA	
	Horizontal shaft		1.5	2.4	3.5	5.8	6.0	6.0	6.0	10	10	11	11	17	17	18	18	23	23	32	60
	Vertical shaft		1.0	1.9	2.0	2.7	2.7	1.1	11	14	14	18	18	23	23	29	29	42	42	51	(60)

() with trochoid pump. 0, 5, or H is inserted in □.

(4) Oil Supply

- Be sure to fill with oil when the unit is not operating.
- When the viscosity of oil is high, it may take some time for the oil to settle. Be careful not to over-fill.
(If oil is filled above the upper line, the temperature will rise due to the churning heat of the oil or oil will leak into the motor through the slinger see Fig.13).

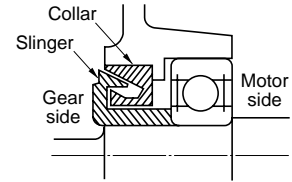

Fig. 13

Oil supply for Horizontal Type (Refer to Fig.14)

- The standard location of the oil gauge on a horizontal unit is on the right side (viewed from the slow speed shaft side). However, since the oil gauge may be placed on either side, select the side most convenient for observation.

- ① Remove the oil filler plug.
- ② Fill oil through oil filler port while checking oil level by the oil gauge.
- ③ Fill oil the upper line on the oil gauge.
- ④ Replace the oil filler plug.

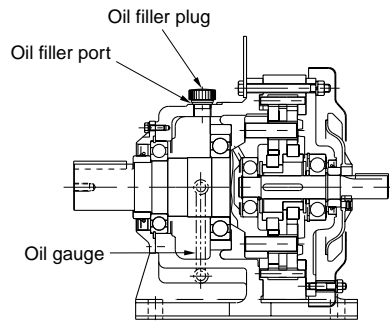
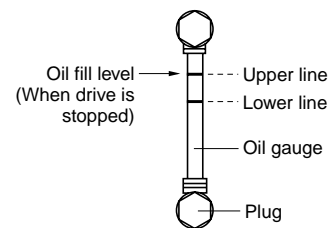

Fig. 14



Oil supply for Vertical Type (Refer to Fig.15)

- ① Remove the oil filler plug and, except for sizes 6255 and 6265, also remove the airvent.
- ② Fill oil through oil filler port while checking oil level by the oil gauge.
- ③ Fill oil the upper line on the oil gauge.
- ④ **Except for Sizes 6255 and 6265**, apply water proof sealing tape to threads of the air vent plug before re-installing.
- ⑤ Replace the oil filler plug.

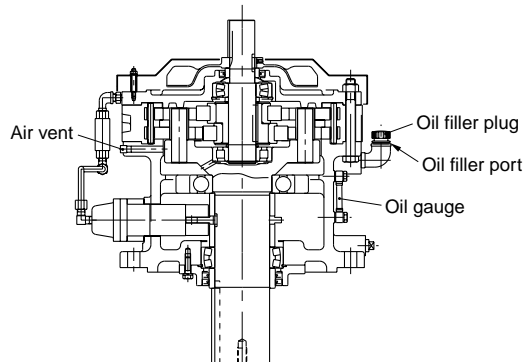
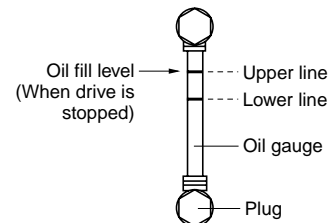

Fig. 15



(5) Oil Discharge

Remove the drain plug shown in Fig. 16 or the lower plug shown in Fig. 17 to discharge oil.

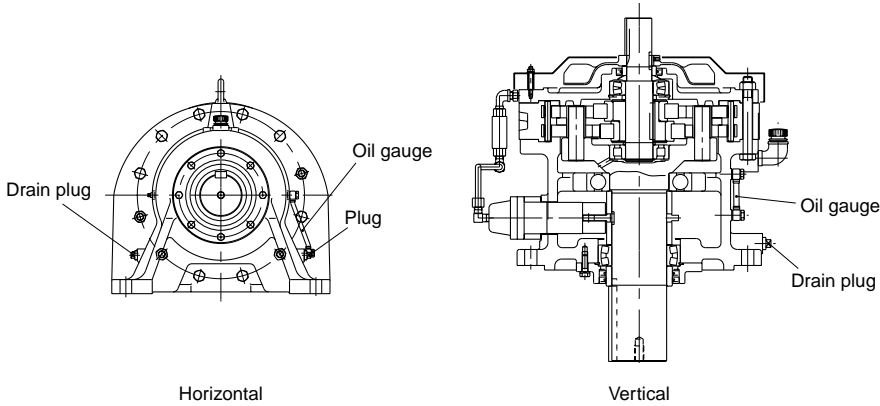

Fig. 16

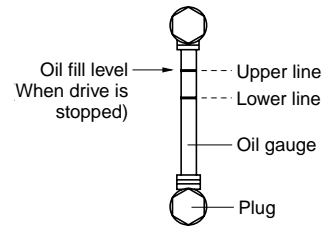

Fig. 17

(6) Long-term Stoppage

Table 20 Long-Term Stoppage

Stoppage Period	Approx. 1 month	Change the oil and operate the unit for several minutes before stopping the unit.
	More than 1 month	Flush the unit, fill with rust-preventive oil, and operate the unit without a load for several minutes before stopping the unit.

• Before starting operation after long-term stoppage, always change the oil. This will ensure that the lubricant is free from deterioration that may have been caused by long-term stoppage.

8-4) Grease Replenishment and Change for Gear Portion

(1) Grease Replenishment/Change Interval

Table 21 Grease Supply/Change Intervals

Model	Grease supply/change interval
Maintenance-free series (□ section in Table 14 on page 17)	Long-life grease (ALVANIA GREASE RA) is supplied with these models, so operation can continue for extended periods. However, disassembly to change the grease after 20,000 hr or 3 to 5 years operation will ensure longer service life.
Grease-lubricated models other than maintenance-free	Refer to Tables 22 and 23 for supply and change of grease.

Table 22 Grease Replenishment Interval (Excl. maintenance-free type)

Hours of operation	Replenishment interval	Remarks
10 hr max./day	3~6 months	Reduce the supply interval when the operating conditions are severe or the frame size is large.
10~24 hr/day	500~1,000 hr	

Table 23 Grease Change Interval (Excl. maintenance-free type)

Change interval	Remarks
Every 20,000 hr or 3~5 years	Reduce the supply interval when the operating conditions are severe or the frame size is large.

(2) Recommended Grease

Table 24 Recommended Grease

Ambient temperature (°C)	Model		
	i) Maintenance-free series (□ section in Table 14 on page 17)	ii) Other grease model	
	Showa Shell Sekiyu	Cosmo Oil	Showa Shell Sekiyu
-10~50	ALVANIA GREASE RA	COSMO GREASE DYNAMAX SH No.2	ALVANIA GREASE 2

- Do not use any grease other than those shown in Table 24.
- Models ii) in Table 24 are filled with COSMO GREASE DYNAMAX SH No.2 before shipment from our factory.
- The two kinds of grease for ii) in Table 24 may be mixed with each other.
- When the ambient temperature continuously exceeds the range of 0~40°C, modifications are needed.

(3) Quantity of Grease

Table 25 shows the quantity of grease Required when grease needs to be changed. Approximately 1/3~1/2 of the volume for the reduction mechanism section is appropriate.

Table 25 Qty of Grease

Single reduction	Frame size	606□	607□	608□	609□	610□	611□	612□																						
	Reduction portion	Qty of grease (g)								25	25	65	90	140	200	330														
	Slow speed shaft bearing portion	Qty of grease (g)								35	35	70	100	100	90	120														
Double reduction	Frame size	606□DA	607□DA	609□DA	610□DA	612□DA	612□DB	613□DA	613□DB	613□DC	614□DA	614□DB	614□DC	616□DA	616□DB	616□DC	617□DA	617□DB	617□DC											
	1st stage (I/P side) reduction portion	Qty of grease (g)								25				90	25	90	140	25	90	140	90	140	330	90	140	330				
	2nd stage (O/P side) reduction portion	Qty of grease (g)								25	90	140	330	450				750				1000								
	2nd stage (O/P side) slow speed shaft bearing portion	Qty of grease (g)								35	35	100	100	120	300												500			
	Frame size	618□DA	618□DB	619□DA	619□DB	6205DA	6205DB	6215DA	6215DB	6225DA	6225DB	6235DA	6235DB	6245DA	6245DB	6255DA	6255DB	6265DA												
1st stage (I/P side) reduction portion	Qty of grease (g)		140	450	330	450	330	450	750	450	1000	750	1100	750	1100	1000	1500	1500												
2nd stage (O/P side) reduction portion	Qty of grease (g)		1100		1500		1500		2000		2500		4000		4500		6000		8000											
2nd stage (O/P side) slow speed shaft bearing portion	Qty of grease (g)		600		700		700		800		900		1000		1100		1200		1300											

- : Maintenance-free Series
- Space/volume ratio : Ratio of grease to the volume of space
- 0, 5, or H is inserted in □.

(4) Supply and Discharge of Grease

Procedure for supplying grease for **grease-lubricated models** (excl. maintenance-free type)

- ① Remove the grease discharge plug from the outside cover.
- ② Supply grease with a grease gun through the grease nipple in the inside cover section or motor connection cover.
- ③ Replace the grease discharge plug.

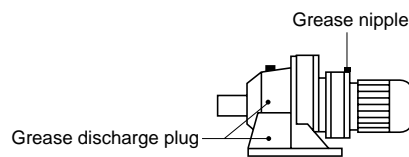

Fig. 18 Location of Grease Discharge Port

- Fill with grease during operation to ensure proper, uniform circulation.
- Fill with grease slowly.
- Grease supply exceeding the quantity shown in Table 25 will cause temperature rise from agitation heat or leakage of grease into the motor.
- Apply grease liberally to bearings (especially to eccentric bearings), pins, rollers, and toothed section of the cyclo discs. (Refer to 11. Construction Drawing on pages 30 and 31.)

Grease change for **grease-lubricated models and maintenance-free series** is something missing here?



8-5) Maintenance of Motor Bearing

The maintenance for **Sumitomo standard 3-phase motor** is shown below.

(Refer to the respective instruction manuals for the **brakemotor**, **servomotor**, **DC motor and Bearing type**; maintenance methods also differ according to motor size. Before maintenance, check the bearing type on the rating plate and Table 26)

Table 26 Bearing Type

Bearing type	Motor frame size		Note
	Load side	Opposite side	
Shield bearing	Smaller than 160#	Smaller than 250#	No grease nipple
Open bearing	Bigger than 180# and frame size over than 6235	---	With grease nipple and discharge plug

Maintenance of **shield bearing**

Refer to [8-6 Maintenance of Parts] (Page 24)

Grease replenishment for **open bearing**

(1) Grease Replenishment Intervals and Quantity

Check the bearing no, on the rating plate, refer to Table 27 and supply grease.

Table 27 Grease Replenishment Intervals and Quantity for Open Bearing

Bearing No.	Dimension (mm)			Initial q'ty (g)	Replenished q'ty (g)	Grease replenishment intervals (Total times every motor speed (r/min))					
	I. D	O. D	W			750r/min	900r/min	1000r/min	1200r/min	1500r/min	1800r/min
6314	70	150	35	200	40	8500	7000	6000	5000	3500	2500
6315	75	160	37	230	45	8500	6500	6000	4500	3500	2500
6316	80	170	39	260	50	8000	6500	5500	4500	3000	2500
6317	85	180	41	300	55	7500	6000	5000	4000	3000	2000
6318	90	190	43	350	60	7000	5500	5000	4000	2500	2000
6319	95	200	45	400	65	7000	5500	4500	3500	2500	1500
6320	100	215	47	450	70	6500	5000	4500	3500	2000	1500
6321	105	225	49	500	75	6000	5000	4000	3000	2000	1500
6322	110	240	50	550	80	6000	4500	4000	3000	2000	1000
6324	120	260	55	700	100	5500	4000	3500	2500	1500	1000
6412	60	150	35	200	40	8500	7000	6000	5000	3500	3000
6413	65	160	37	230	45	8000	6500	6000	4500	3500	2500
6414	70	180	42	300	55	8000	6500	5500	4500	3000	2500
NU314	70	150	35	120	40	4000	3500	3000	2500	1500	1000
NU315	75	160	37	150	45	4000	3000	3000	2000	1500	1000
NU316	80	170	39	200	50	4000	3000	2500	2000	1500	1000
NU317	85	180	41	250	55	3500	3000	2500	2000	1500	1000
NU318	90	190	43	300	60	3500	2500	2500	2000	1000	1000
NU319	95	200	45	350	65	3500	2500	2000	1500	1000	
NU320	100	215	47	400	70	3000	2500	2000	1500	1000	
NU321	105	225	49	450	75	3000	2500	2000	1500	1000	
NU322	110	240	50	500	80	3000	2000	2000	1500	1000	
NU324	120	260	55	650	100	2500	2000	1500	1000		

- "Initial q'ty" shows quantity of grease for disassembled and cleaned inside of the unit. Paint 1/3 of grease with the inner lace of bearing and replenish other with inside of the unit.
- "Replenished q'ty" shows quantity of grease for every replenishment.
- For intermittent operation, replenish grease every 3 years or less.
- For long-term stoppage replenish grease just after operating.



(2) Recommended Grease

Table 28 Recommended Grease

Ambient temperature °C	Open bearing	
	E, B Insulation	F Insulation
	Showa Shell Sekiyu	
-10~40	Alvania Grease 2	Darina Grease 2

- Do not use any grease other than those shown in Table 28.

(3) Grease Supply and Discharge (Refer to Fig.19 and Fig.39, 40 on page 32)

- ① Remove the discharge plug, discharge old grease and add new grease while unit is operating.
(Grease replenishment at rest cause an insufficient grease change.)
- ② Replace the discharge plug after 10min operation.

- Excessive grease may cause temperature rise of bearing or leakage of grease.
- Exceeding the recommended amount of grease does not extend the replenishment interval.
- Don't neglect daily inspection; otherwise abnormal wear and noise from the motor, damage to the bearing may result.

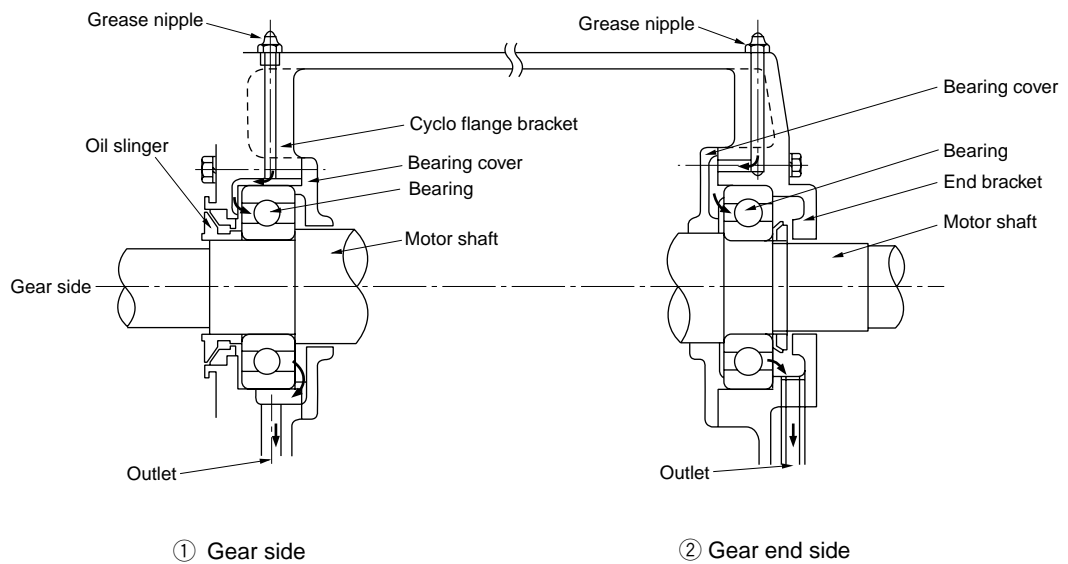

Fig. 19 Construction of Open Bearing in the Motor

8-6) Maintenance of Parts

We recommend overhauling the gearmotor or reducer after 20,000 hours or 4 to 5 years of operation to ensure longer service life; this is dependent on the operating conditions.

Contact our service office, if necessary. Although our technician should perform overhauls, the customer should identify and provide appropriate corrective action according to Table 29, if performing disassembly and inspection.

Table 29 Maintenance of Parts

Parts		Material	Correction	
Gear portion	Cyclo disc	Bearing steel	• Replace if pitted or teeth are damaged.	
	Ring gear pin	↑	• Replace if part is damaged.	
	Slow speed shaft pin	↑		
	Slow speed shaft roller	↑		
	Bearing	↑	• Replace if part is damaged.	
	Oil seal	Nitril rubber	• Replace. • Apply grease (or oil) on the lip of the oil seal during assembly. • JIS D type (Spring loaded, rubber covered with dust lip) is recommended for dust-proof.	
	Oil level gauge	Oil-proof special vinyl (Standard)	Replace when discolored parts make it difficult to check oil level.	
	Oil signal	Polycarbonate (Transparent pipe)	Clean discolored parts with neutral cleanser.	
	Gasket		Paper gasket for low (medium) surface pressure (manufactured by Three Bond Co., Ltd.)	• Replace. • Apply liquid gasket (Three Bond 1102 etc.) on both surfaces of paper gasket, during assembly.
Three Bond 1215 (Liquid gasket : manufactured by Three Bond Co., Ltd.)			• Apply liquid gasket on both surfaces of parts after flashing oil.	
Motor portion	Bearing	Open type	Bearing steel	• Replace. Grease is damaged.
		Sealed type	↑	• Replace if part is damaged.
	Oil slinger collar (Only for motor of 6130-6165)		Nitril rubber	• Replace. • Apply grease on the lip of the oil seal during assembly.

- Since wear and tear on the oil seals, collar, oil level gauge, oil signal and gasket may result in oil leakage, handle all parts carefully during disassembly and assembly. Replace parts showing any signs of deterioration.
- Apply Three Bond 1215 to ⑥ gasket A, ⑭ gasket B and ⑰ gasket C in **frame size 6205~6265, 6205DA~6265DA, 6205DB~6255DB** (Refer Fig.28 on Page 30 and Fig.34 on Page 31)
- Items listed in the "Material" column of Table 29 are standard accessories. Consult us if the ambient is non-standard since some of them are different from standard one.
- Use CM class (distance) bearing for the motor bearing.
- Use grease (Kyodo Yushi : Multemp SRL) lubricated bearing for the sealed motor bearing.
- Use the roller bearing with a bronze retainer for the motor bearing.
- Change new V ring for antiloading side.
Grease up V ring rip when assembling.

9. Disassembly and Assembly

⚠ DANGER

- Customers shall not disassemble or modify **explosion-proof type motors**; otherwise, explosion, ignition, electric shock or damage to the equipment may result.

⚠ CAUTION

- Trained technicians should repair, disassemble and assemble gearmotors or reducers; otherwise, electric shock, personal injury, fire, or damage to the equipment may result.

- To avoid injury, take care when working around keyways and parts having sharp edges. Observe all safety precautions.
- Avoid disassembling gearmotors or reducers in dusty or humid locations.
- Keep screws and other small parts in a box to avoid losing them.
- Take care not to damage parts. Avoid contact with dust and water.
- After disassembly, clean and inspect all parts. Replace all damaged parts.

9-1) Disassembly of Gear Portion (Single reduction)

Discharge oil from the oil lubricated unit before the disassembly.
(Refer to [8-3 (5) Discharge of Oil] on Page 20)

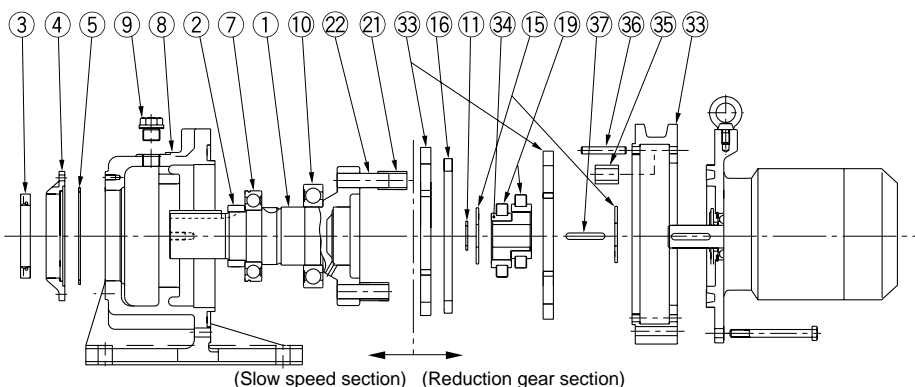

Fig. 20

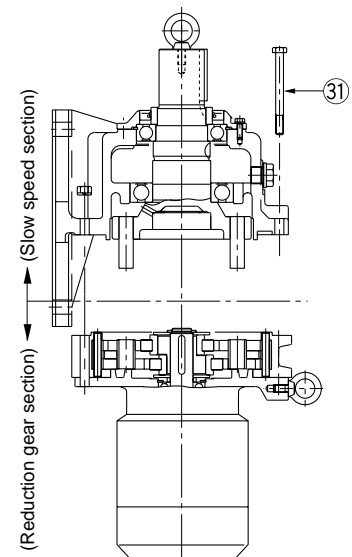

Fig. 21

Disassembly of main parts

Follow these steps to disassemble the unit: (Refer to Fig. 20, 21 and Fig. 27, 31 on Page 30)

- (1) Place the drive with the slow speed section up → Remove the bolts for ring gear housing ③① → Separate the slow speed section
- (2) Reduction gear section
Slow speed shaft roller ②① → Retaining ring ①① (**Larger than frame size 6120**) → High speed shaft bearing A ①② (**Reducer** and **smaller than frame size 6115 gearmotor**). Refer to Fig.28 on Page 30 → Spacer ①⑤ → Cyclo disc A ③③ → Spacer ring ①⑥ (**Larger than frame size 6100**) → Eccentric ③④ (With eccentric bearing ①⑨) or eccentric bearing ⑤⑥ (Refer to Fig.32 on Page 30) → Cyclo disc B ③③ (Larger than frame size 6100) → Key ③⑦ → Spacer ①⑤ → Ring gear pin ③⑥ → Ring gear roller ③⑤
- (3) High speed section (Refer to Fig.28 on Page 30) ...High speed end shield ②⑩ to high speed shaft ②⑥ disassembly.
Fan cover ②④ → Fan ②③ (**Larger than frame size 6160**) → Retaining ring ③⑩ (**Frame size 6060-6265**) or bearing plate (**Frame size 6275**) → High speed shaft ②⑥ (With high speed shaft bearing B ②⑨ and collar ②⑦)
- (4) Slow speed section
Slow speed end cap ④ → Retaining ring ⑤ → Slow speed shaft ① (With slow speed shaft bearing A ⑦, B ⑩ and collar ②)

9-2) Assembly of Gear Portion (single reduction)

Assembly procedures are the reverse of the disassembly procedures.

- (1) Since wear and tear on the oil seals, collars, gaskets, oil signal, etc. may lead to oil leakage, they should be replaced with new parts in accordance with the procedures described in Table 29 on Page 24.
- (2) When assembling balance weight (**Frame size 6060~6095**), the stamped face of the weight should be facing you.
- (3) Replacement of the eccentric bearing
 - One cyclo disc model (Frame size 606□*, 607□, 609□)**
 - Fit the bearing with the eccentric so that the unstamped sides are on the same level.
(**Frame size 606□, 607□, refer to Fig. 22**)
 - When assembling the eccentric to the shaft, the stamped side of one should be facing you.
 - One cyclo disc model (Frame size 608□)**
 - Fit cyclo disc at center of the bearing (Refer Fig. 24)
 - When assembling the eccentric to the shaft, the stamped side of one should be facing you.
 - Two cyclo disc model (Frame size 610□, 612□~616□)**
 - When assembling the eccentric to the shaft, the stamped side of one should be facing you.
 - Two cyclo disc model (Frame size 611□, 617□~6275)**
 - Fit the bearing to the eccentric assembly so that the stamps are facing outwards to each other. (Refer to Fig. 23)
- (4) **In frame sizes 6100~6275**, the two cyclo discs should be placed with the stamps on each disc facing you at an angle of 180 degrees opposite to each other. (Refer to Fig. 25)
- (5) In the vertical type with a plunger pump, the roller at the extended end of the pump should be assembled so that the roller is in contact with the cam ④ (Fig. 29 on Page 30) to enable it to rotate. At that time, the position should be fixed with the UP mark on the pump at the top side (**Frame size 6205 through 6265**) or a knock pin (**Frame size 6160 through 6195**).
- (6) After assembling, confirm that there is no abnormality and test-run the unit.

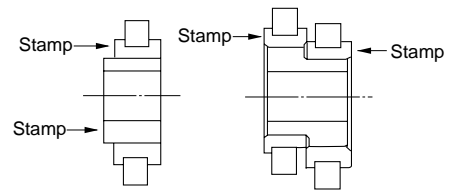

Fig. 22

Fig. 23



Fig. 24

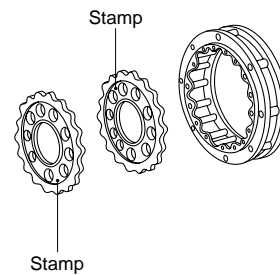

Fig. 25

*0, 5, or H is inserted in □.

9-3) Disassembly of Gear Portion (Double reduction)

- Discharge oil from the oil lubricated unit before the disassembly. {Refer to [8-3 (5) Discharge of oil] on Page 20}
- Disassembly procedures for double reduction are basically the same as those for single reduction.
Disassemble second stage first and then the first stage according to Fig. 26 and 27 on Page 27. {Refer to [Disassembly of gear portion (single reduction)] on Page 25}

9-4) Assembly of Gear Portion (Double reduction)

- Assembly procedures are the reverse of the disassembly procedures.

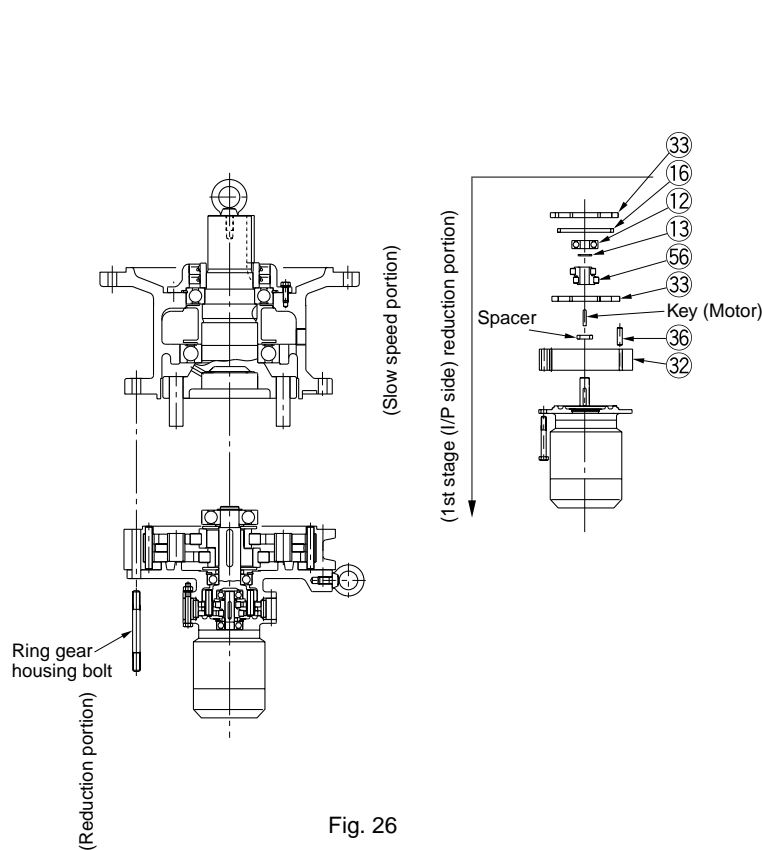

Fig. 26

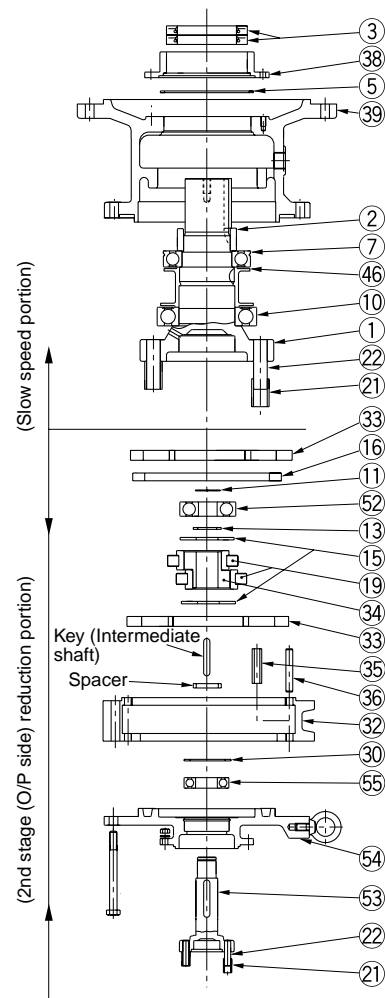

Fig. 27

9-5) Disassembly and Assembly of Motor

When disassembling and assembling motor, take care the following.

- (1) Avoid assembling or disassembling the stationary core and bearing in a dusty, humid or wet location.
- (2) When the unit is used under severe duty, such as fluctuating load or vibration, we recommend applying a small amount of loctite to the outer race of the bearing. (Recommended: Loctite 242 or 271)
- (3) Apply Three bond 1324D to inner race of the oil slinger collar of on the rotation side (P32, Fig.40, No.14) for **6130~6165** or, the bottom side of oil seal collar.
- (4) When assembling an outdoor motor, remove the old liquid gasket and re-apply.
- (5) After assembling, confirm that there is no abnormality and test-run the unit.

10. Troubleshooting

If a problem occurs with the gearmotor or reducer, refer to Table 30 below and take the appropriate corrective action as soon as possible. If the problem can not be eliminated, contact out nearest agent, dealer or sales office.

Table 30 Troubleshooting



Problem		Possible cause	Correction	
	The motor will not operate under load.	Power failure	Contact the electric power company.	
		Defective electric circuit	Check the circuit.	
		Blown fuse	Replace the fuse.	
		Protective device is engaged	Disengage protective device.	
		Load locking	Check the load and safety device.	
		Poor switch contact	Adjust the contact area.	
		Disconnection of motor stator coil	Return the unit to factory for servicing.	
		Bearing is broken	Replace the bearing.	
		3-phase is functioning as single-phase.	Check the power supply with a voltmeter. Check the motor, coil in the transformer, contact, fuse, etc. and repair or replace them.	
The motor runs without a load but the output shaft does not rotate.		Damage due to overloading of gears	Return the unit to factory for servicing.	
The output shaft turns without a load	When a load is applied	The switch is heated.	Insufficient capacity of switch	Replace with specified switch.
			Overload	Decrease the load to the specified value.
		Fuse tripping	Insufficient capacity of fuse	Replace with specified fuse.
			Overload	Decrease the load to the specified value.
		The speed will not increase and the motor is overheating.	Voltage drop	Contact the electric power company.
			Overload	Decrease the load to the specified value.
	The motor stops.	Short-circuited motor stator coil	Return the unit to factory for servicing.	
		The key is missing	Install a key.	
		The bearing is burned.	Replace the bearing.	
	The motor runs in the reverse direction.	Poor adjustment of protective device	Adjust the protective device.	
		Connection error	Change the connection.	
		Fuse tripping	The outlet wire is short-circuited.	Return the unit to factory for servicing.
Excessive temperature rise		Poor contact between motor and starter	Complete the connection.	
		Overload	Decrease the load to the specified value.	
		Voltage drop or rise	Contact the electric power company.	
		The ambient temperature is high.	Improve the ventilation method.	
		Damaged bearing	Replace the bearing.	
Oil leakage	Leakage of oil/grease into motor	Abnormal wear of Cyclo disc due to overloading	Replace the Cyclo disc.	
		Damaged oil seal	Replace the oil seal.	
		Loose bolts	Tighten bolts correctly.	
Abnormal sound Abnormal vibration		Damaged oil seal	Return the unit to factory for servicing.	
		Excessive oil/grease supply	Remove excess oil/grease.	
		Entry of dust and foreign matter into bearings or damaged bearings.	Replace the bearing.	
		Entry of foreign matter into Cyclo disc.	Remove the foreign matter and check the damage.	
		Damaged Cyclo disc.	Replace the Cyclo disc.	
		Distortion of housing because the installation surface is not flat	Make the installation base flat or make adjustment using shims.	
		Resonance due to insufficient rigidity of installation base	Reinforce the installation base to increase rigidity.	
Nonalignment of shaft with driven machine	Align the shaft centers.			
Abnormal sound from motor 		Transmission of vibration from the driven machine	Individually operate the gearmotor or reducer to check the source of the sound.	
		Entry of foreign matter	Remove the foreign matter.	
		Damaged bearings	Replace the bearing.	

Table 30 Troubleshooting

Problem		Possible cause	Correction
 Inverter tripping	Shut-off due to overcurrent	Sudden acceleration/deceleration	Increase the acceleration/deceleration time.
		Sudden change in load	Decrease the load.
	Grounding overcurrent	Grounding on the output side	Make correction to eliminate grounding.
	DC overcurrent	Short-circuiting on the output side	Make correction to eliminate short-circuiting. Check cables.
	Shut-off due to regenerative overvoltage	Sudden deceleration	Increase the deceleration time. Reduce the braking frequency.
	Thermal relay operation	Overloading	Decrease the load to the specified value.

11. Construction Drawing

11-1) Construction of Gearmotor and Reducer

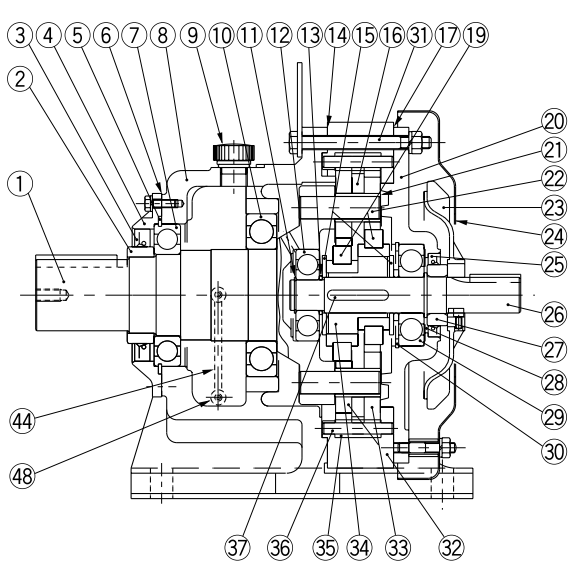

Fig. 28 Type CHH (Horizontal • Reducer)
Single Reduction (Example : Frame size 6175)

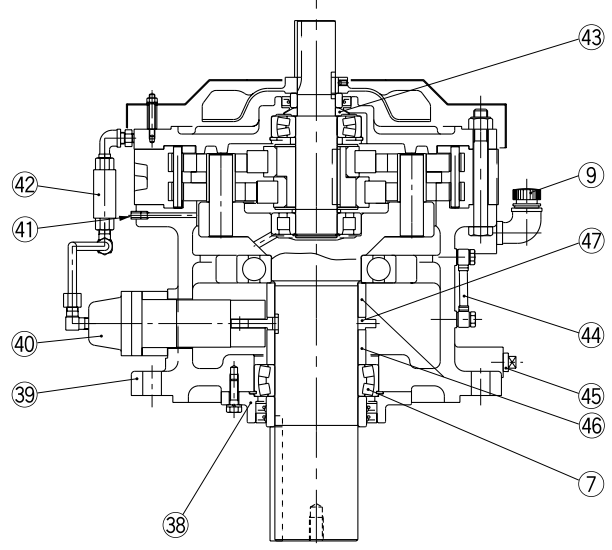

Fig. 29 Type CVV (Vertical • Reducer)
Single Reduction (Example : Frame size 6225)

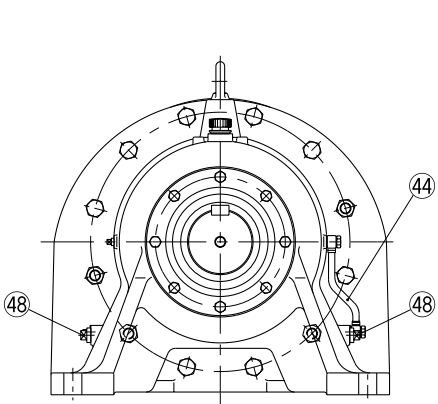

Fig. 30 Type CHHM (Horizontal • Gearmotor), Single Reduction (Example : Frame size 6225)

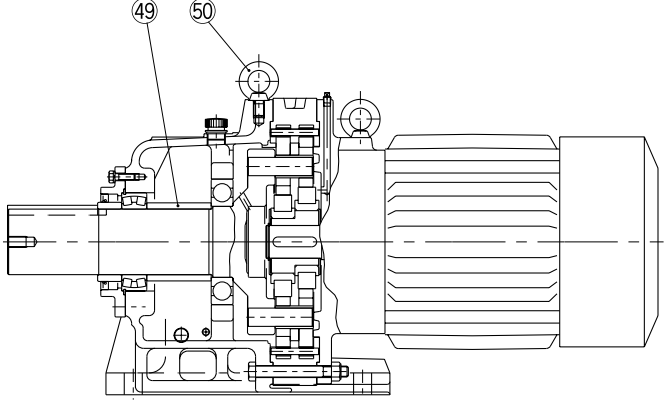

Fig. 31 Type CNHM (Horizontal • Gearmotor)
Single Reduction (Example : Frame size 6095)

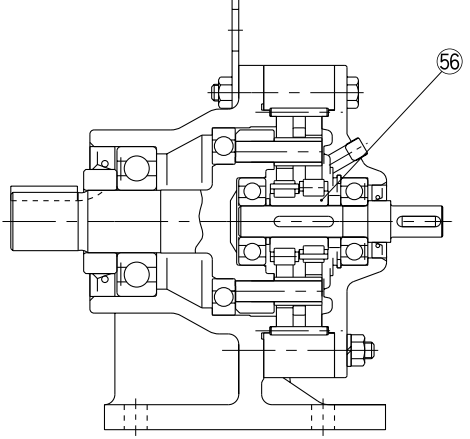

Fig. 32 Type CNH (Horizontal • Reducer)
Single Reduction (Example : Frame size 6105)

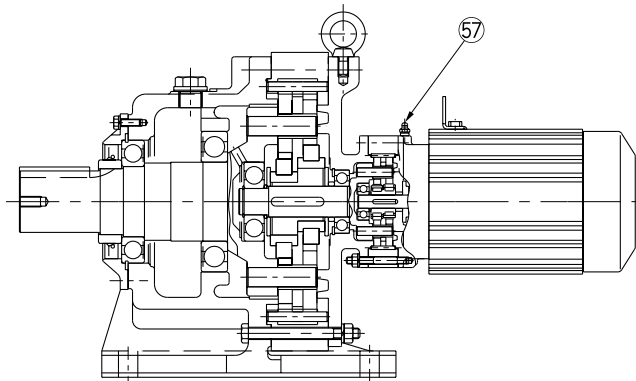

Fig. 33 Type CHHM (Horizontal • Gearmotor)
Double Reduction (Example : Frame size grease lubricated 6185DB)

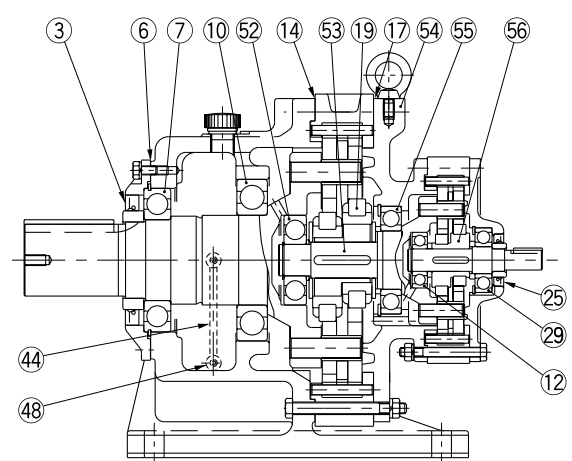

Fig. 34 Type CHH (Horizontal • Reducer)
Double Reduction (Example : Frame size 6185DB)

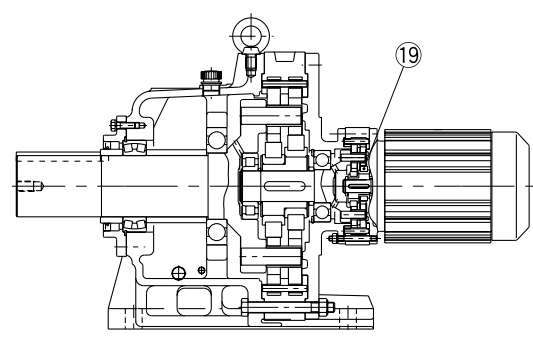

Fig. 35 Type CHHM (Horizontal • Gearmotor)
Double Reduction (Example : Frame size 6225DB)

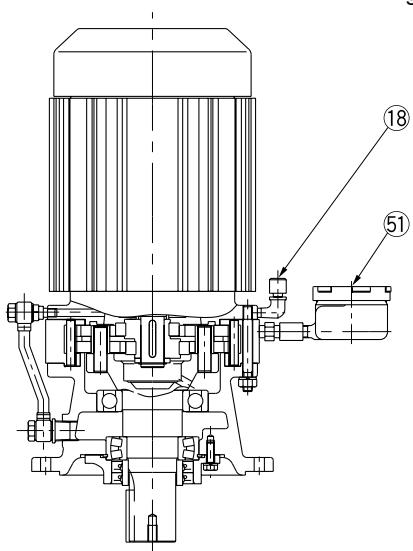

Fig. 36 Type CVVM (Vertical • Gearmotor)
Single Reduction (Example : Frame size 6145)

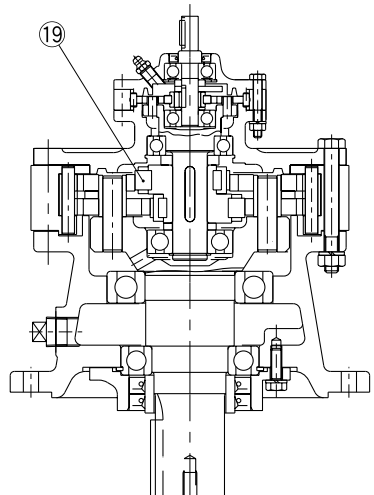

Fig. 37 Type CVV (Vertical • Reducer)
Double Reduction (Example : Frame size 6135DA)

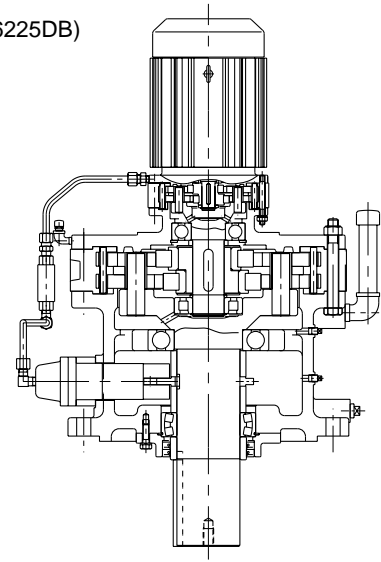

Fig. 38 Type CVVM (Vertical • Gearmotor)
Double Reduction (Example : Frame size 6225DA)

Table 31 Principal Parts

No.	Part Name	No.	Part Name	No.	Part Name	No.	Part Name	No.	Part Name
1	Slow speed shaft	13	Spacer	25	Oil seal	37	Key	49	Spacer
2	Collar (Slow speed shaft)	14	Gasket B	26	High speed shaft	38	Gland	50	Eye bolt
3	Oil seal	15	End plate	27	Collar (High speed shaft)	39	Flanged casing	51	Oil filler
4	Slow speed end cap	16	Spacer ring	28	Spacer	40	Plunger pump	52	Intermediate shaft, bearing A
5	Retaining ring	17	Gasket C	29	High speed shaft, bearing B	41	Air vent plug	53	Intermediate shaft
6	Gasket A	18	Air vent plug	30	Retaining ring	42	Oil signal	54	Intermediate cover
7	Slow speed shaft, bearing A	19	Bearing for eccentric (High speed shaft section)	31	Bolt for ring gear housing	43	Oil slinger	55	Intermediate shaft, bearing B
8	Horizontal casing	20	High speed end shield	32	Ring gear housing	44	Oil lever gauge	56	Eccentric bearing (Double)
9	Oil filler plug	21	Slow speed shaft roller	33	Cycloid disc	45	Plug (Oil drain)	57	Grease nipple
10	Slow speed shaft, bearing B	22	Slow speed shaft pin	34	Eccentric	46	Spacer		
11	Retaining ring	23	Cooling fan	35	Ring gear roller	47	Cam		
12	High speed shaft, bearing A	24	Fan cover	36	Ring gear pin	48	Plug (Oil drain)		

11-2) Construction Drawing of Motor (for direct coupling with Cyclo drive)

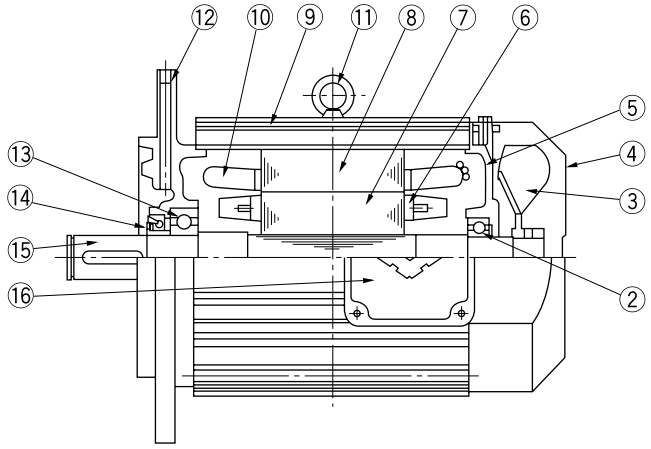

Fig. 39 Example of Construction of 80-112M Frame

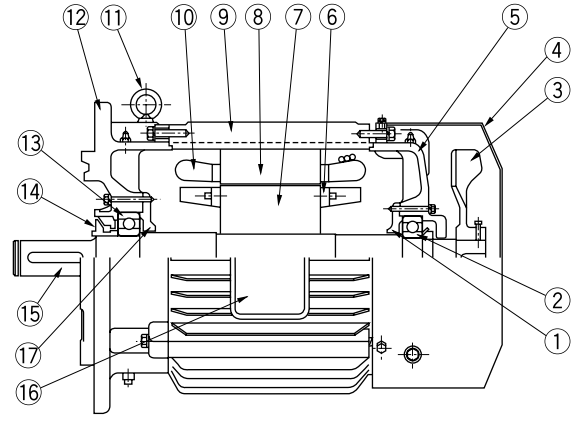

Fig. 40 Example of Construction of Frame Size 180 or Above

Table 32 Main Parts of Motor

No.	Part Name	No.	Part Name	No.	Part Name
1	Bearing cover	7	Rotor core	13	Motor shaft bearing A
2	Motor shaft bearing B	8	Stationary core	14	Oil slinger (Oil seal)
3	Fan	9	Stator frame	15	Motor shaft
4	Fan cover	10	Stator windings	16	Conduit box
5	End bracket	11	Eyebolt	17	Bearing cover
6	Rotor conductor short circuit ring	12	Cyclo flange bracket		

12. List of Bearings and Oil Seals

12-1) Bearings

Refer to Tables 33~36 for the model of each bearings.

Table 33 Slow Speed Shaft Bearing

Frame size		Slow speed shaft	
Single reduction	Double reduction	Bearing A	Bearing B
606□ *	606□DA	6204Z	6909
607□	607□DA	6204Z	6909
608□	—	6305Z	6009
609□	609□DA	6306Z	16011
610□	610□DA	6306Z	16011
611□	—	6307Z	6011
612□	612□DA, 612□DB	6308Z	6013
613□	613□DA, 613□DB, 613□DC	6211NR	6213
614□	614□DA, 614□DB, 614□DC	22211EXNR	6213
616□	616□DA, 616□DB, 616□DC	*3TM-6213NR	*6215
617□	617□DA, 617□DB, 617□DC	*6216NR	*6218
618□	618□DA, 618□DB	*6218NR	*6220
619□	619□DA, 619□DB	*6221NR	*6026
6205	6205DA, 6205DB	22220BNRC2	6222C2
6215	6215DA, 6215DB	23022BNRC2	6224C2
6225	6225DA, 6225DB	23024BNRC2	6226C2
6235	6235DA, 6235DB	23026BNRC2	NUP228C2
6245	6245DA, 6245DB	23028BNRC2	NUP230C2
6255	6255DA, 6255DB	23032BNRC2	NUP234C2
6265	6265DA	23034BNRC2	NUP236C2
6275	6275DA	23136BNXR	6340

(Note) Refer to the following construction drawing for position of bearing

	Single reduction	Double reduction	No.
Slow speed shaft bearing A	Fig. 28 (P30)	Fig. 34 (P31)	⑦
Slow speed shaft bearing B	Fig. 28 (P30)	Fig. 34 (P31)	⑩

In case of grease lubrication, *marked bearing should be changed for sealed bearing which No. is like the following NR (STD)→ZNR, NXR→ZNXR, None→Z.
 *0, 5, or H is inserted in □.

Table 34 High Speed Shaft Bearing, Motor Shaft Bearing

Frame size		High speed shaft			
Single reduction	Double reduction	High speed shaft bearing A	High speed shaft bearing B	Eccentric bearing	Q'ty
606□ *	606□DA, 607□DA	6301	6301Z	607YXX	1
607□	609□DA, 610□DA, 612□DA, 613□DA, 614□DA	6301	6301Z	607YXX	1
608□	—	6301SH	6302Z	Refer to table 35 Eccentric bearing	1
609□	612□DB, 613□DB, 614□DB, 616□DA, 617□DA	6302RSH2	6302Z		
610□	613□DC, 614□DC, 616□DB, 617□DB, 618□DA	6302RSH2	6302Z		
611□	—	6302RSH2	6302Z		
612□	616□DC, 617□DC, 619□DA, 6205DA	6304	6305Z		
613□	618□DB, 619□DB, 6205DB, 6215DA, 6225DA	6305	6306		
614□	—	6305R	6306		
616□	6215DB, 6235DA, 6245DA	6307R	6308	2	
617□	6255DB, 6255DA	6406	6407		
618□	6235DB, 6245DB	6407	6409	2	
619□	6255DB, 6265DA, 6275DA	6408	6411	2	
6205	—	NJ310EV7	21311V1	620GXX	2
6215	—	NJ311EV16	21311V1	621GXX	2
6225	—	NJ312EV11	21312V1	622GXX	2
6235	—	NJ313EV11	21314V1	623GXX	2
6245	—	NJ314EV7	21315V1	624GXX	2
6255	—	NJ316EV1	21318V1	625GXX	2
6265	—	NJ317EV1	21318V1	626GXX	2
6275	—	NJ417	22222BL1	627GXX	2

*0, 5, or H is inserted in □.

(Note) Refer to the following construction drawing for position of bearing

	Single reduction	Double reduction	No.
High speed shaft bearing A	Fig. 28 (P30)	Fig. 34 (P31)	⑫
High speed shaft bearing B	Fig. 28 (P30)	Fig. 34 (P31)	⑲
Eccentric bearing	Fig. 28 (P30)	Fig. 35 (P31)	⑰

Table 35 Eccentric Bearing

High speed shaft, Motor speed shaft	Frame size					
	6090, 6095	6100, 6105	6120, 6125	6130, 6135	6140, 6145	6160, 6165
Intermediate shaft Reduction ratio	609□DA *	610□DA	612□DA 612□DB	613□DA 613□DB 613□DC	614□DA 614□DB 614□DC	616□DA 616□DB 616□DC
6	60906YRX	6100608YRX	6120608YRX	61406-11YSX	61406-11YSX	6160608YRX2
8	60908-15YSX	6100608YRX	6120608YRX	61406-11YSX	61406-11YSX	6160608YRX2
11	60908-15YSX	61011-15YRX	6121115YSX	61406-11YSX	61406-11YSX	61611-15YSX
13	60908-15YSX	61011-15YRX	6121317YSX	61413-17YSX	61413-17YSX	61611-15YSX
15	60908-15YSX	61011-15YRX	6121115YSX	61413-17YSX	61413-17YSX	61611-15YSX
17	60917YSX	61017YSX	6121317YSX	61413-17YSX	61413-17YSX	61617-25YSX
21	60921YSX	61021YRX	61221YRX	6142125YSX	6142125YSX	61617-25YSX
25	6092529YSX	6102529YRX	6122529YSX	6142125YSX	6142125YSX	61617-25YSX
29	6092529YSX	6102529YRX	6122529YSX	6142935YSX	6142935YSX	6162935YSX
35	60935YSX	61035YRX	61235YRX	6142935YSX	6142935YSX	6162935YSX
43	60943YSX	61043YSX	61243YSX	61443-59YSX	61443-59YSX	6164351YSX
51	60951YRX	61051YRX	6125159YSX	61443-59YSX	61443-59YSX	6164351YSX
59	60959YSX	61059YRX	6125159YSX	61443-59YSX	61443-59YSX	61659YSX
71	60971YRX	61071YRX	6127187YSX	6147187YSX	6147187YSX	61671YRX2
87	60987YSX	61087YRX	6127187YSX	6147187YSX	6147187YSX	61687YSX
119	609119YSX	610119YSX	—	—	—	—

*0, 5, or H is inserted in □.

(Note) Refer to the following construction drawing for position of bearing

Single reduction	No.
Fig. 32 (P30)	⑤
Double reduction	No.
Fig. 37 (P31)	⑱

Table 36 Intermediate Shaft Bearing

Frame size	Intermediate shaft				Frame size	Intermediate shaft			
	Bearing A	Bearing B	Eccentric bearing	Q'ty		Bearing A	Bearing B	Eccentric bearing	Q'ty
606□DA*	6301	6909	607YXX	1	618□DA	6407	6208	618YSX	2
607□DA	6301	6909	607YXX	1	618□DB	6407	6213	618YSX	2
609□DA	6302RSH2	6007	Refer to table 35 Eccentric bearing	1	619□DA	6408	6210	619YSX	2
610□DA	6302RSH2	6007			619□DB	6408	6213	619YSX	2
612□DA	6304	6007			6205DA	NJ310EV7	6210	620GXX	2
612□DB	6304	6205			6205DB	NJ310EV7	6310	620GXX	2
613□DA	6305	6007			6215DA, 6215DB	NJ311EV16	6311	621GXX	2
613□DB	6305	6206			6225DA, 6225DB	NJ312EV11	6313	622GXX	2
613□DC	6305	6206			6235DA, 6235DB	NJ313EV11	6314	623GXX	2
614□DA	6305	6007			6245DA	NJ314EV7	6315	624GXX	2
614□DB	6305	6206			6245DB	NJ314EV7	6316	624GXX	2
614□DC	6305	6206			6255DA, 6255DB	NJ316EV1	6318	625GXX	2
616□DA	6307R	6207			6265DA	NJ317EV1	6320	626GXX	2
616□DB					6275DA	NJ417	22220RH	627GXX	2
616□DC	6307R	6208							
617□DA	6406	6207			617YSX				2
617□DB									
617□DC	6406	6208			617YSX				2

*0, 5, or H is inserted in □.

(Note) Refer to the following construction drawing for position of bearing

	Drawing No.	No.
Intermediate shaft bearing A	Fig. 34 (P31)	52
Intermediate shaft bearing B	Fig. 34 (P31)	55
Eccentric bearing	Fig. 34 (P31)	19

12-2) Oil Seals

Table 37 Oil Seal

Frame size	Slow speed shaft					High speed shaft		
	Type	Dimension mm (I.D.XO.D.XW)	Q'ty		Type	Dimension mm (I.D.XO.D.XW)	Q'ty	
			Horizontal shaft	Vertical shaft				
606□*	D	30 x 47 x 8	1	1	S	17 x 30 x 6	1	
607□	D	30 x 47 x 8	1	1	S	17 x 30 x 6	1	
608□	D	45 x 62 x 9	1	1	S	17 x 30 x 6	1	
609□	D	50 x 72 x 12	1	1	S	20 x 35 x 7	1	
610□	D	50 x 72 x 12	1	1	S	20 x 35 x 7	1	
611□	D	55 x 80 x 12	1	1	S	20 x 35 x 7	1	
612□	D	65 x 90 x 13	1	1	D	32 x 52 x 8	1	
613□	D	65 x 88 x 12	1	2	D	38 x 58 x 11	1	
614□	D	65 x 88 x 12	1	2	D	38 x 58 x 11	1	
616□	D	85 x 110 x 13	1	2	D	55 x 78 x 12	1	
617□	D	95 x 130 x 15	1	2	D	60 x 82 x 12	1	
618□	D	110 x 145 x 15	1	2	D	65 x 88 x 12	1	
619□	D	120 x 155 x 16	1	2	S	70 x 88 x 10	1	
6205	D	120 x 155 x 16	1	2	S	70 x 88 x 10	1	
6215	D	130 x 160 x 14	1	2	S	75 x 100 x 13	1	
6225	D	145 x 175 x 14	1	2	S	75 x 100 x 13	1	
6235	D	160 x 190 x 16	1	2	S	85 x 110 x 13	1	
6245	D	170 x 200 x 16	1	2	S	95 x 120 x 13	1	
6255	D	190 x 225 x 16	1	2	S	110 x 140 x 14	1	
6265	D	200 x 240 x 20	1	2	S	110 x 140 x 14	1	
6275	D	230 x 270 x 20	1	2	S	120 x 150 x 14	1	

*0, 5, or H is inserted in □.

(Note) Refer to the following construction drawing for position of bearing

	Single reduction	Double reduction	No.
Slow speed shaft oil seal	Fig. 2(P30)	Fig. 34 (P31)	3
High speed shaft oil seal	Fig. 2(P30)	Fig. 34 (P31)	25

Table 38 Type and Shaft of Oil Seal

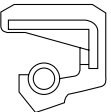
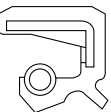
Type	Shape	NOK	Koyo Chicago Rawhide
S	Circumferential rubber with spring (JIS S type) 	SC	MHS
D	Dust-proofing circumferential rubber with spring (JIS D type) 	TC	MHSA

(JIS B2402-1976 Oil seal)

13. Warranty

The scope of our warranty for our products is limited to the range of our manufacture.

Warranty (period and contents)

Warranty Period	The warranty for new Cyclo, units shall be 24 months from date of shipment.
Warranty Condition	<p>In the event that any problem or damage to the Product arises during the "Warranty Period" from defects in the Product whenever the Product is properly installed and combined with the Buyer's equipment or machines, maintained as specified in the maintenance manual, and properly operated under the conditions described in the catalog or as otherwise agree upon in writing between the Seller and the Buyer or its customers; the Seller will provide, at its sole discretion, appropriate repair or replacement of the Product, without charge, at a designated facility, except as stipulated in the "Warranty Exclusions" described below.</p> <p>However, if the Product is installed or integrated into the Buyer's equipment or machines, the Seller shall not reimburse the cost of: removal or re-installation of the Product or other incidental costs related thereto, any lost opportunity, any profit loss or other incidental or consequential losses or damages incurred by the Buyer or its customers.</p>
Warranty Exclusions	<p>Notwithstanding the above warranty, the warranty as set forth herein shall not apply to any problem or damage to the Product that is caused by :</p> <ol style="list-style-type: none"> 1. installation, connection, combination or integration of the Product in or to the other equipment or machine that is rendered by any person or entity other than the Seller ; 2. insufficient maintenance or improper operation by the Buyer or its customers, such that the Product is not maintained in accordance with the maintenance manual provided or designated by the Seller ; 3. improper use or operation of the Product by the Buyer or its customers that is not informed to the Seller, including, without limitation, the Buyer's or its customers' operation of the Product not in conformity with the specifications, or use of lubricating oil in the Product that is not recommended by the Seller ; 4. any problem or damage to any equipment or machine to which the Product is installed, connected or combined, or on any specifications particular to the Buyer or its customers ; 5. any changes, modifications, improvements or alterations to the Product or those functions that are rendered on the Product by any person or entity other than the Seller ; 6. any parts in the Product that are supplied or designated by the Buyer or its customers ; 7. earthquake, fire, flood, sea-breeze, gas, thunder, acts of God or any other reasons beyond the control of the Seller ; 8. normal wear and tear, or deterioration of the Product's parts, such as bearings, oil-seals ; 9. any other troubles, problems or damage to the Product that are not attributable to the Seller.

Worldwide Sumitomo Network

U.S.A

Sumitomo Machinery
Corporation of America
4200 Holland Blvd.,
Chesapeake, VA 23323
Tel : (1)757-485-3355
Fax: (1)757-487-3193

Canada

SM-Cyclo of Canada, Ltd.
870A Equestrian Court Oakville,
Ontario, Canada L6L 6L7
Tel : (1)905-469-1050
Fax: (1)905-469-1055

Mexico

SM-Cyclo De Mexico, S.A. de C.V.
Calle "C" No. 506A
Parque Industrial Almacentro
Apodaca, N. L., Mexico 66600
Tel : (52)8-369-3697
Fax: (52)8-369-3699

Brazil

SM-Cyclo Redutores Do Brasil Ltda.
Av. Dr. Ulysses Guimarães,
3533, 09990-080 Diadema,
São Paulo, Brazil
Tel : (55)11-4071-4388
Fax: (55)11-4071-2922

Chile

SM-Cyclo De Chile, Ltda.
Avenida Zanartu #1231, Comuna Nunoa,
Casilla No.22 Santiago 60, Chile
Tel : (56)2-237-2407
Fax: (56)2-237-0225

United Kingdom

Sumitomo (SHI) Cyclo Drive Europe, Ltd.
Marfleet Kingston Upon Hull HU9 5RA,
United Kingdom
Tel : (44)1482-788022
Fax: (44)1482-713205

SM-Cyclo U.K. Ltd.

Marfleet Kingston Upon Hull HU9 5RA,
United Kingdom
Tel : (44)1482-790340
Fax: (44)1482-790321

France

SM-Cyclo France E.U.R.L.
65/75 Avenue Jean Mermoz
F-93120 La Courneuve France
Tel : (33)149-929494
Fax: (33)149-929490

Italy

SM-Cyclo Italy S.r.l.
Via dell' Artigianato 23 20010
Cornaredo (Mi)
Tel : (39)02-9356-2121
Fax: (39)02-9356-9893

Netherlands

SM-Cyclo Benelux BV
Den Engelsman 16D NL-6026 RB
Maarheeze The Netherlands
Tel : (31)495599777
Fax: (31)495593177

Sweden

SM-Cyclo Scandinavia AB
Företagsvägen 30A S-232 37
Arlöv Sweden
Tel : (46)40430220
Fax: (46)40431001

Spain

SM-Cyclo Iberia, S.L.
Pol.Ind.C/En Proyecto no.29, Parc.66,
Nave B 46470 Catarroja (Valencia)
Spain
Tel : (34)9-6-1264461
Fax: (34)9-6-1265602

Switzerland

SM-Cyclo Switzerland AG
Lerzenstrasse 27 CH8953 Dietikon
Tel : (41)56-6-33 0441
Fax: (41)56-6-33 0442

Belgium

SMBE Branch Belgium Office
Gentsesteenweg 1387
B-1082 Brüssel
Tel : (32)2-469-0517
Fax: (32)2-469-0207

South Africa

SM-Cyclo of South Africa
Proprietary Ltd.
P. O. Box 2808, Edenvale 1610
78 Watt Street, Meadowdale
Germiston 1401
Tel : (27)11-974-3145
Fax: (27)11-974-2530

Germany

Sumitomo (SHI) Cyclo Drive
Germany, GmbH
Cyclostraße 92 D-85229 Markt Indersdorf
Tel : (49)8136-66-0
Fax: (49)8136-5771

SCG Branch Hannover Office
Auf dem kessel lande 4 30900
Wedemark
Tel : (49)5130-7922-71
Fax: (49)5130-7922-79

Austria

SCG Branch Austria Office
Weinheberstraße 9 A-4020 Linz
Tel & Fax: (43)732-330766

China

Sumitomo (SHI) Cyclo Drive Tianjin, Ltd.
No. 7 Sanijing Road Dongli Economic
Development Zone, Tianjin
Tel : (86)22-2499-3501
Fax: (86)22-2499-3133

Singapore

Sumitomo (SHI) Cyclo Drive
Asia Pacific Pte., Ltd.
No.36 Tuas South Street 3,
Singapore 638031
Tel : (65)863-2238
Fax: (65)863-4238

Malaysia

SM-Cyclo of Malaysia Sdn. Bhd.
No.2, Jalan TP 7/5,
Sime-uep Industrial Park,
40400 Shah Alam,
Selangor Malaysia
Tel : (60)3-5128909
Fax: (60)3-5128809

Thailand

SM-Cyclo of Thailand Co., Ltd.
195, Empire Tower
Unit 1504, 15th Floor
South Sathorn Road, Yannawa Sathorn
Bangkok 10120, Thailand
Tel : (66)2-670-0998
Fax: (66)2-670-0999

India

SM-Cyclo of India Private Ltd.
Flat No 201 K. G. Mansion
1233/C Apte Road, Deccan Gymkhana
Pune-4, India
Tel : (91)20-553-4651
Fax: (91)20-553-4658

Australia

SM-Cyclo of Australia Pty., Ltd.
13 Centre Place, Wetherill Park,
NSW 2164
Tel : (61)2-9756-2455
Fax: (61)2-9756-2002

Philippine

SCA Branch Philippines Office
Unit 504, Amberland Plaza
Condominium, Julia Vargas Ave.,
Ortigas Center Metro Manila
Tel : (63)2-637-2106
Fax: (63)2-632-7372

Taiwan

Tatung SM-Cyclo Co., Ltd.
22 Chungshan N. Road.,
3rd Sec. Taipei, Taiwan, 104 R.O.C.
Tel : (886)2-2595-7275
Fax: (886)2-2595-5594

Korea

SM-Cyclo of Korea Co., Ltd.
Royal Bldg. 9F. Rm. 913
5 Danju-dong chongro-ku
Seoul 110
Tel : (82)2-730-0151
Fax: (82)2-730-0156

POWER TRANSMISSION & CONTROLS GROUP

 **Sumitomo Heavy Industries, Ltd.**

5-9-11, KITA-SINAGAWA SINAGAWA-KU, TOKYO 141-8686, JAPAN
PHONE: (03)5488-8363 FAX: (03)5488-8355

Home page <http://www.shi.co.jp/ptc/>